

MET colonna: com'è realizzata

MET Hochschrank: wie er gemacht ist

MET columna: cómo está hecho

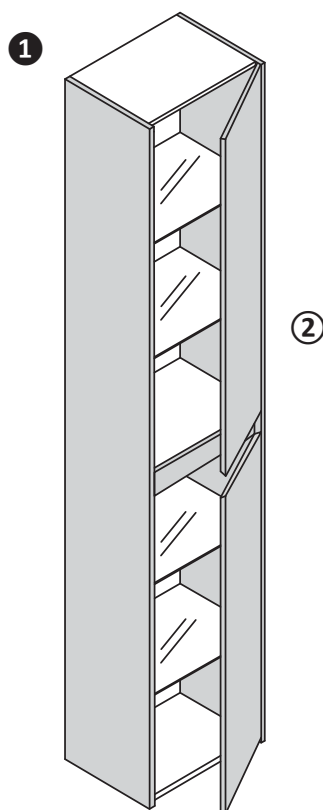

① Colonna

Realizzato con differenti materiali, naturali o tecnologici.

Struttura realizzata con pannelli in melaminico Classe E1, W100 impiallacciato legno, oppure con pannelli MDF Classe E1 verniciati,

② Frontali con apertura a gola sagomata con taglio a 45° realizzati in:

- Finiture laccate con pannello in MDF Classe E1
- Finiture legno con impiallacciatura di vero legno
- Finiture legno Jazz con impiallacciatura di vero legno su pannello in MDF Classe E1 colore nero

② Hochhängeschränke

Hergestellt mit verschiedenen Materialien, sowohl natürlich als auch technologisch.

Struktur aus Melaminplatten E1-Klasse, W100 Holz furnierplatten oder aus lackierten E1-Klasse MDF-Platten.

② Fronten mit geformter Griffmulde mit 45° -Schnitt, hergestellt aus:

- Lackierte Endfertigung mit MDF-Platten der Klasse E1
- Holz ausführung mit Echtholz furnier
- Jazz-Holz ausführung mit Echtholz furnier auf MDF-Platte Klasse E1 in schwarzer Farbe

② Columnas

Hecho con diferentes materiales, naturales o tecnológicos.

Estructura hecha con paneles de melamina Clase E1, de chapa de madera, W100, o con paneles de MDF pintados Clase E1.

② Frentes con apertura a gola con corte de 45° hechos de:

- Acabados lacados con panel MDF Clase E1
- Acabados de madera con chapa de madera real
- Acabado de madera Jazz con chapa de madera real sobre panel MDF clase E1 en color negro

Met: materiali e finiture

Met: Materialien und Endfertigungen

Met: materiales y acabados

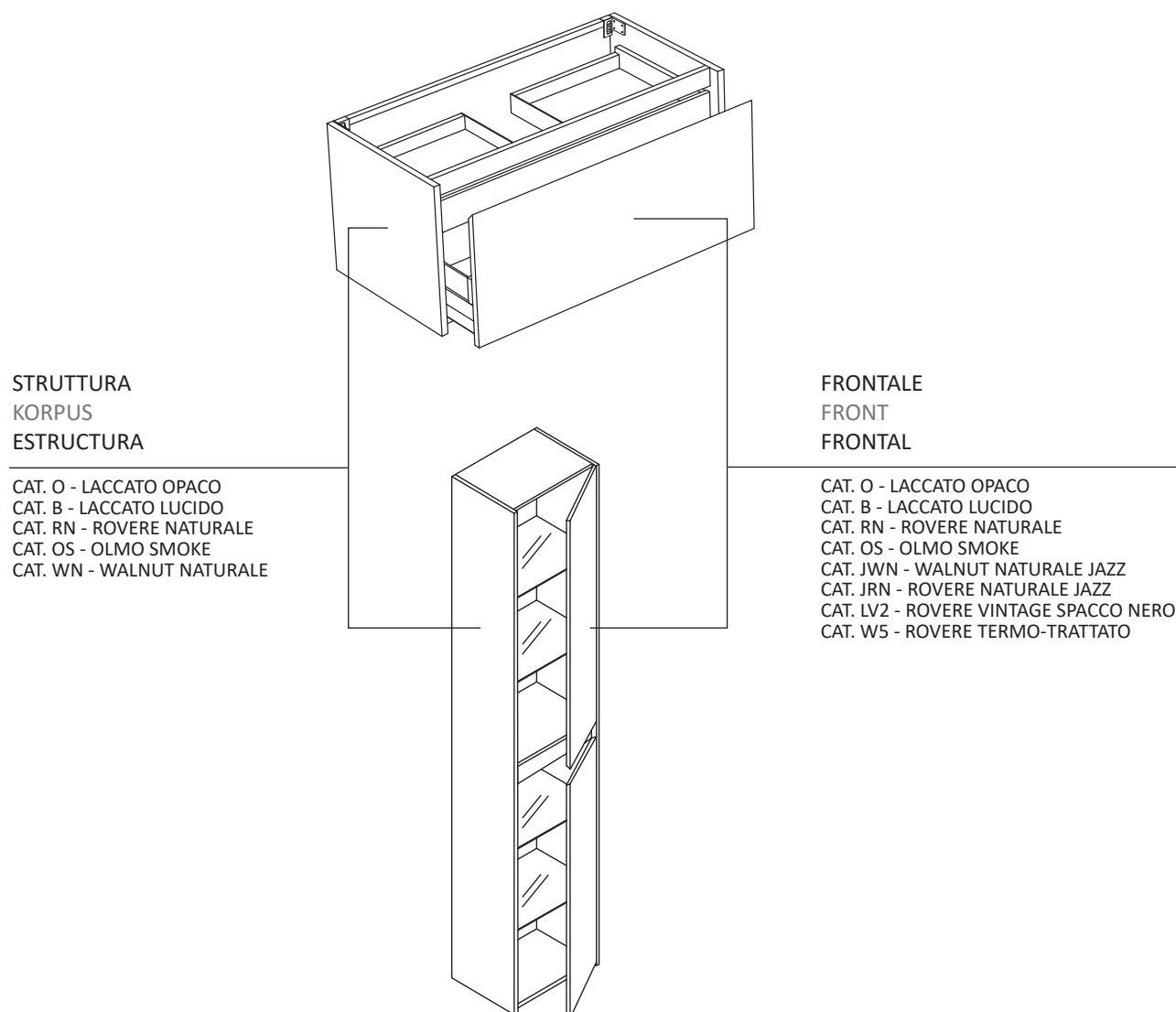

STRUTTURA
KORPUS
ESTRUCTURA

CAT. O - LACCATO OPACO
CAT. B - LACCATO LUCIDO
CAT. RN - ROVERE NATURALE
CAT. OS - OLMO SMOKE
CAT. WN - WALNUT NATURALE

FRONTALE
FRONT
FRONTAL

CAT. O - LACCATO OPACO
CAT. B - LACCATO LUCIDO
CAT. RN - ROVERE NATURALE
CAT. OS - OLMO SMOKE
CAT. JWN - WALNUT NATURALE JAZZ
CAT. JRN - ROVERE NATURALE JAZZ
CAT. LV2 - ROVERE VINTAGE SPACCO NERO
CAT. W5 - ROVERE TERMO-TRATTATO

Attenzione: il legno è un prodotto naturale; pertanto l'azienda non può garantire la corrispondenza con i campioni. Qualsiasi variazione del colore, venatura o effetto del legno deve considerarsi non contestabile, rappresentando pregio del materiale e delle lavorazioni artigianali.

Achtung: Holz ist ein Naturprodukt, deshalb kann das Unternehmen nicht die Übereinstimmung mit den Mustern garantieren. Jede Abweichung in der Farbe, Maserung oder im Effekt des Holzes muss als nicht beanstandbar angesehen werden, da es ein Zeichen des Werts des Materials und der handwerklichen Verarbeitung darstellt.

Atención: la madera es un producto natural; por tanto la empresa no puede garantizar la correspondencia con las muestras. Todas variaciones del color, venas o efectos de la madera no pueden ser cuestionados, ya que representan el valor del material y de los trabajos artesanales.

Struttura: materiali e finiture

Korpus: Materialien und Endfertigungen

Estructura: materiales y acabados

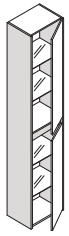

LACCATO / LACKIERT / LACADO

CAT. O - Laccato opaco / Matt lackiert / Lacado mate

CAT. B - Laccato lucido / Glänzend lackiert / Lacado brillante

PoppingTrend



O. 283 - B. 282
Salice



O. 281 - B. 280
Savana



O. 36 - B. 113
Bordeaux



O. 285 - B. 284
Oriente



O. 287 - B. 286
Oceano



O. 190 - B. 189
Oltremare

FeelingSoft



O. 182 - B. 181
Salvia



O. 271 - B. 270
Tahiti



O. 273 - B. 272
Santorini



O. 275 - B. 274
Lavanda



O. 277 - B. 276
Lilla



O. 279 - B. 278
Pesca

ForeverChic

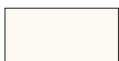

O. 20 - B. 21
Bianco

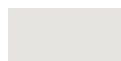

O. 231 - B. 230
Perla



O. 233 - B. 232
Seta

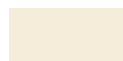

O. 235 - B. 234
Alpaca



O. 172 - B. 171
Lino



O. 180 - B. 179
Avana



O. 237 - B. 236
Argilla



O. 174 - B. 173
Corda



O. 239 - B. 238
Pietra



O. 241 - B. 240
Cervino



O. 243 - B. 242
Dolomiti



O. 245 - B. 244
Arizona



O. 247 - B. 246
Cipria



O. 249 - B. 248
Erica



O. 251 - B. 250
Terra



O. 253 - B. 252
Granata



O. 255 - B. 254
Bosco



O. 257 - B. 256
Oliva



O. 259 - B. 258
Canapa



O. 261 - B. 260
Cotone



O. 263 - B. 262
Efeso



O. 265 - B. 264
Lavaredo



O. 267 - B. 266
Pamir



O. 269 - B. 268
Bromo



O. 198 - B. 104
Grafite



O. 46 - B. 100
Nero

FenixLike



O. 289 - B. 288
Ottawa



O. 291 - B. 290
Londra



O. 263 - B. 262
Efeso



O. 269 - B. 268
Bromo



O. 295 - B. 294
Jaipur



O. 297 - B. 296
Orinoco



O. 293 - B. 292
Fes

LEGNO / HOLZ / MADERA

Venatura verticale / Senkrechte Maserung / Grano vertical

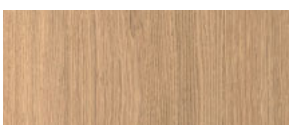

CAT. RN

Legno Rovere naturale



CAT. OS

Legno Olmo Smoke

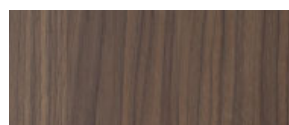

CAT. WN

Legno Walnut naturale

Frontali: materiali e finiture

Fronten: Materialien und Endfertigungen

Frontales: materiales y acabados

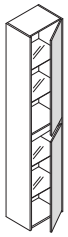

LACCATO / LACKIERT / LACADO

CAT. O - Laccato opaco / Matt lackiert / Lacado mate

CAT. B - Laccato lucido / Glänzend lackiert / Lacado brillante

PoppingTrend



O. 283 - B. 282
Salice



O. 281 - B. 280
Savana



O. 36 - B. 113
Bordeaux



O. 285 - B. 284
Oriente



O. 287 - B. 286
Oceano



O. 190 - B. 189
Oltremare

FeelingSoft



O. 182 - B. 181
Salvia



O. 271 - B. 270
Tahiti



O. 273 - B. 272
Santorini



O. 275 - B. 274
Lavanda



O. 277 - B. 276
Lilla



O. 279 - B. 278
Pesca

ForeverChic

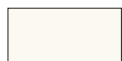

O. 20 - B. 21
Bianco

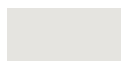

O. 231 - B. 230
Perla



O. 233 - B. 232
Seta

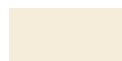

O. 235 - B. 234
Alpaca



O. 172 - B. 171
Lino



O. 180 - B. 179
Avana



O. 237 - B. 236
Argilla



O. 174 - B. 173
Corda



O. 239 - B. 238
Pietra



O. 241 - B. 240
Cervino



O. 243 - B. 242
Dolomiti



O. 245 - B. 244
Arizona



O. 247 - B. 246
Cipria



O. 249 - B. 248
Erica



O. 251 - B. 250
Terra



O. 253 - B. 252
Granata



O. 255 - B. 254
Bosco



O. 257 - B. 256
Oliva



O. 259 - B. 258
Canapa



O. 261 - B. 260
Cotone



O. 263 - B. 262
Efeso



O. 265 - B. 264
Lavaredo



O. 267 - B. 266
Pamir



O. 269 - B. 268
Bromo



O. 198 - B. 104
Grafite



O. 46 - B. 100
Nero

FenixLike



O. 289 - B. 288
Ottawa



O. 291 - B. 290
Londra



O. 263 - B. 262
Efeso



O. 269 - B. 268
Bromo



O. 295 - B. 294
Jaipur



O. 297 - B. 296
Orinoco



O. 293 - B. 292
Fes

Frontali: materiali e finiture

Fronten: Materialien und Endfertigungen

Frontales: materiales y acabados

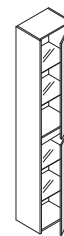

LEGNO JAZZ / HOLZ JAZZ / MADERA JAZZ

Venatura verticale / Senkrechte Maserung / Grano vertical



CAT. JRN

Legno Rovere naturale Jazz

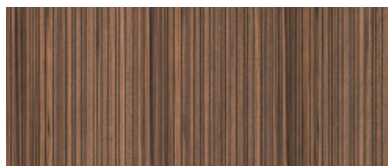

CAT. JWN

Legno Walnut Jazz

LEGNO / HOLZ / MADERA

Venatura verticale / Senkrechte Maserung / Grano vertical

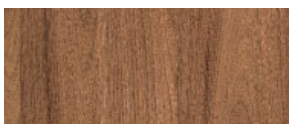

CAT. OS

Legno Olmo Smoke

Venatura orizzontale / Waagerechte Maserung / Grano horizontal



CAT. RN

Legno Rovere naturale



CAT. LV2

Legno Rovere Vintage
con spacco nero



CAT. W5

Legno Rovere
termo-trattato