

# MET colonne : en détail

MET kolomkast: hoe wordt het gemaakt

MET column: how it is made

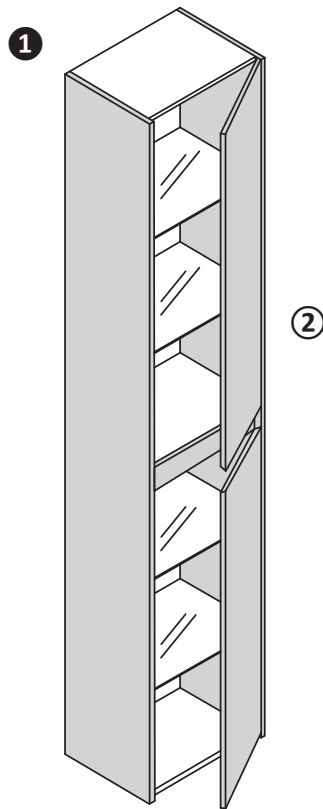

## ② MEUBLE

Réalisé avec différents matériaux, naturels ou technologiques.

Caisson réalisé avec panneaux avec panneaux en mélamine Classe E1, W100 placage de bois, ou avec panneaux MDF de Classe E1 vernis.

② Façades avec ouverture à gorge avec coupe à 45° en :

- Finitions laquées avec panneau MDF Classe E1
- Finitions bois avec placage de bois véritable
- Finition bois jazz avec placage de bois véritable sur panneau MDF classe E1 de couleur noire

## ② Hoge kast

Van verschillende natuurlijke of technische materialen.

Structuur met met melamine panelen klasse E1, W100 houtfineer of gelakte MDF-panelen klasse E1.

② Frontelementen met verzonken 45° profielgreep:

- Gelakte afwerkingen met MDF-paneel klasse E1
- Houtafwerking met echt houtfineer
- Jazz houtafwerking met echt houtfineer op MDF-plaat van klasse E1 in zwarte kleur

## ② Columns

Made of different materials, natural or technological,

Structure realized with melamine panels Class E1, W100 wood veneer panels, or with painted E1 Class MDF panels.

② Fronts with shaped groove opening with 45° cut made of:

- Lacquered finishes with MDF panel Class E1
- Wood finishes with real wood veneer
- Jazz wood finish with real wood veneer on MDF board class E1 in black color.

# Met : matériaux et finitions

Met: materialen en afwerkingen

Met: materials and finishes

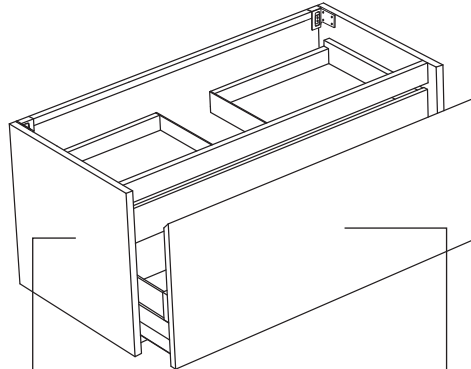

## CAISSON STRUCTUUR STRUCTURE

CAT. O - LACCATO OPACO  
CAT. B - LACCATO LUCIDO  
CAT. RN - ROVERE NATURALE  
CAT. OS - OLMO SMOKE  
CAT. WN - WALNUT NATURALE

## FAÇADE VOORZIJDEN FRONT

CAT. O - LACCATO OPACO  
CAT. B - LACCATO LUCIDO  
CAT. RN - ROVERE NATURALE  
CAT. OS - OLMO SMOKE  
CAT. JWN - WALNUT NATURALE JAZZ  
CAT. JRN - ROVERE NATURALE JAZZ  
CAT. LV2 - ROVERE VINTAGE SPACCO NERO  
CAT. W5 - ROVERE TERMO-TRATTATO

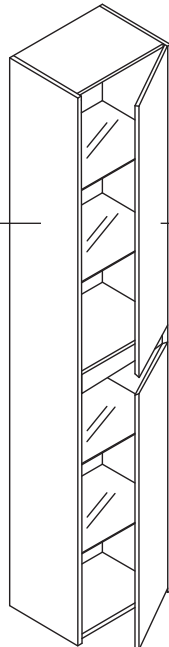

Attention : le bois est un produit naturel; pourtant ce n'est pas possible de garantir la correspondance aux échantillons. Les variations de la couleur, veines ou effet du bois ne peuvent pas être contestées : elles représentent la valeur du matériel et des travaux artisanales.

Opgepast: hout is een natuurlijk product, om die reden kan het bedrijf niet exact hetzelfde resultaat als dat van de monsters garanderen. Iedere afwijking in kleur, nerven of een ander effect in het hout kan niet het onderwerp van een klacht uitmaken, gezien het een kenmerk is, dat eigen is aan het materiaal en aan de ambachtelijke behandelingen.

Attention: wood is a natural product; therefore the company can not guarantee correspondence with the samples. Any variation of the color, grain or effect of the wood must be considered not contestable, representing the value of the material and of the craftsmanship.

# Caisson : matériaux et finitions

Structuur: materialen en afwerkingen

Structure: materials and finishes

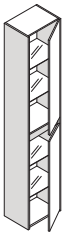

## LAQUÉ / GELAKT / LACQUERED

**CAT. O** - Laqué mat / Mat gelakt / Matt lacquered

**CAT. B** - Laqué brillant / Glanzend gelakt / Glossy lacquered

### PoppingTrend



O. 283 - B. 282  
Salice



O. 281 - B. 280  
Savana



O. 36 - B. 113  
Bordeaux



O. 285 - B. 284  
Oriente



O. 287 - B. 286  
Oceano



O. 190 - B. 189  
Oltremare

### FeelingSoft



O. 182 - B. 181  
Salvia



O. 271 - B. 270  
Tahiti



O. 273 - B. 272  
Santorini



O. 275 - B. 274  
Lavanda



O. 277 - B. 276  
Lilla



O. 279 - B. 278  
Pesca

### ForeverChic



O. 20 - B. 21  
Bianco

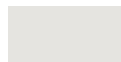

O. 231 - B. 230  
Perla



O. 233 - B. 232  
Seta

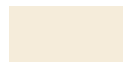

O. 235 - B. 234  
Alpaca



O. 172 - B. 171  
Lino



O. 180 - B. 179  
Avana



O. 237 - B. 236  
Argilla



O. 174 - B. 173  
Corda



O. 239 - B. 238  
Pietra



O. 241 - B. 240  
Cervino



O. 243 - B. 242  
Dolomiti



O. 245 - B. 244  
Arizona



O. 247 - B. 246  
Cipria



O. 249 - B. 248  
Erica



O. 251 - B. 250  
Terra



O. 253 - B. 252  
Granata



O. 255 - B. 254  
Bosco



O. 257 - B. 256  
Oliva



O. 259 - B. 258  
Canapa



O. 261 - B. 260  
Cotone



O. 263 - B. 262  
Efeso



O. 265 - B. 264  
Lavaredo



O. 267 - B. 266  
Pamir



O. 269 - B. 268  
Bromo



O. 198 - B. 104  
Grafite



O. 46 - B. 100  
Nero

### FenixLike



O. 289 - B. 288  
Ottawa



O. 291 - B. 290  
Londra



O. 263 - B. 262  
Efeso



O. 269 - B. 268  
Bromo



O. 295 - B. 294  
Jaipur



O. 297 - B. 296  
Orinoco



O. 293 - B. 292  
Fes

## BOIS / HOUT / WOOD

Veinage vertical / Verticale nerf / Vertical grain



**CAT. RN**

Legno Rovere naturale



**CAT. OS**

Legno Olmo Smoke



**CAT. WN**

Legno Walnut naturale

# Façades : matériaux et finitions

Voorzijden: materialen en afwerkingen

Fronts: materials and finishes

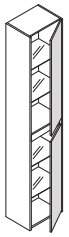

## LAQUÉ / GELAKT / LACQUERED

**CAT. O** - Laqué mat / Mat gelakt / Matt lacquered

**CAT. B** - Laqué brillant / Glanzend gelakt / Glossy lacquered

### PoppingTrend



O. 283 - B. 282  
Salice



O. 281 - B. 280  
Savana



O. 36 - B. 113  
Bordeaux



O. 285 - B. 284  
Oriente



O. 287 - B. 286  
Oceano



O. 190 - B. 189  
Oltremare

### FeelingSoft



O. 182 - B. 181  
Salvia



O. 271 - B. 270  
Tahiti



O. 273 - B. 272  
Santorini



O. 275 - B. 274  
Lavanda



O. 277 - B. 276  
Lilla



O. 279 - B. 278  
Pesca

### ForeverChic



O. 20 - B. 21  
Bianco

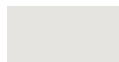

O. 231 - B. 230  
Perla



O. 233 - B. 232  
Seta



O. 235 - B. 234  
Alpaca



O. 172 - B. 171  
Lino



O. 180 - B. 179  
Avana



O. 237 - B. 236  
Argilla



O. 174 - B. 173  
Corda



O. 239 - B. 238  
Pietra



O. 241 - B. 240  
Cervino



O. 243 - B. 242  
Dolomiti



O. 245 - B. 244  
Arizona



O. 247 - B. 246  
Cipria



O. 249 - B. 248  
Erica



O. 251 - B. 250  
Terra



O. 253 - B. 252  
Granata



O. 255 - B. 254  
Bosco



O. 257 - B. 256  
Oliva



O. 259 - B. 258  
Canapa



O. 261 - B. 260  
Cotone



O. 263 - B. 262  
Efeso



O. 265 - B. 264  
Lavaredo



O. 267 - B. 266  
Pamir



O. 269 - B. 268  
Bromo



O. 198 - B. 104  
Grafite



O. 46 - B. 100  
Nero

### FenixLike



O. 289 - B. 288  
Ottawa



O. 291 - B. 290  
Londra



O. 263 - B. 262  
Efeso



O. 269 - B. 268  
Bromo



O. 295 - B. 294  
Jaipur



O. 297 - B. 296  
Orinoco



O. 293 - B. 292  
Fes

# Façades : matériaux et finitions

Voorzijden: materialen en afwerkingen

Fronts: materials and finishes



## BOIS JAZZ / HOUT JAZZ / WOOD JAZZ

Veinage vertical / Verticale nerf / Vertical grain



### **CAT. JRN**

Legno Rovere naturale Jazz

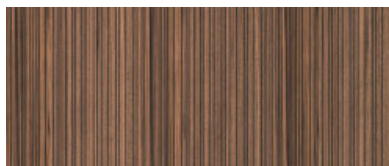

### **CAT. JWN**

Legno Walnut Jazz

## BOIS / HOUT / WOOD

Veinage vertical / Verticale nerf / Vertical grain

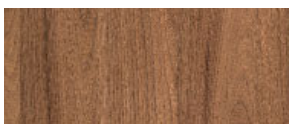

### **CAT. OS**

Legno Olmo Smoke

Veinage horizontal / Horizontale nerf / Horizontal grain



### **CAT. RN**

Legno Rovere naturale



### **CAT. LV2**

Legno Rovere Vintage  
con spacco nero



### **CAT. W5**

Legno Rovere  
termo-trattato