



Met

P 51 cm



# Met: com'è realizzato

Met: wie es gemacht ist

Met: cómo está hecho

## ① LAVABI

Top con lavabo integrato disponibile in varie forme e materiali.

## ① WASCHBECKEN

Waschtischplatte mit integriertem Waschbecken erhältlich in verschiedenen Formen und Materialien.

## ① LAVABOS

Encimera con lavabo integrado disponible en varias formas y materiales.

①

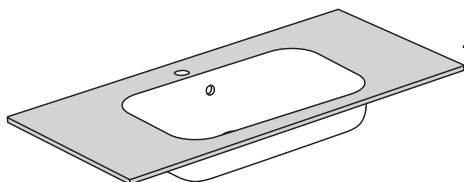

②

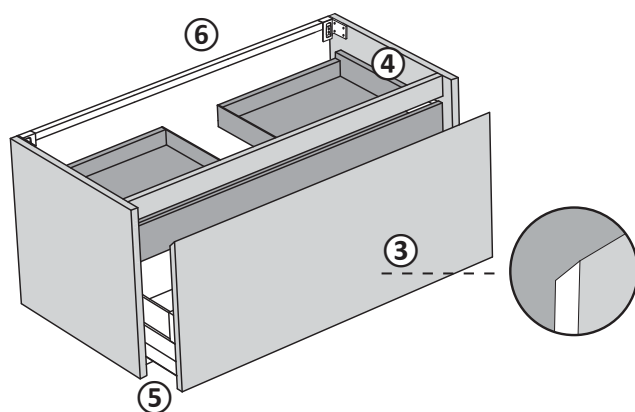

## ② MOBILE

Realizzato con differenti materiali, naturali o tecnologici.

Struttura realizzata con pannelli in melaminico Classe E1, W100 impiallacciato legno, oppure con pannelli MDF Classe E1 verniciati,

③ Frontali con apertura a gola sagomata con taglio a 45° realizzati in:

- Finiture laccate con pannello in MDF Classe E1

- Finiture legno con impiallacciatura di vero legno

- Finiture legno Jazz con impiallacciatura di vero legno su pannello in MDF Classe E1 colore nero

④ Struttura interna realizzata con pannelli in melaminico Classe E1, W100 colore grigio antracite

⑤ Cassetti in metallo verniciato e vetro, chiusura soft-system

⑥ Installazione a muro con attacchi a parete regolabili, barre strutturali in alluminio utilizzabili come sistema antiscandalo.

## ② MÖBEL

Hergestellt mit verschiedenen Materialien, sowohl natürlich als auch technologisch.

Struktur aus Melaminplatten E1-Klasse, W100 Holz furnierplatten oder aus lackierten E1-Klasse MDF-Platten.

③ Fronten mit geformter Griffmulde mit 45° -Schnitt, hergestellt aus:

- Lackierte Endfertigung mit MDF-Platten der Klasse E1

- Holzausführung mit Echtholz furnier
- Jazz-Holzausführung mit Echtholz furnier auf MDF-Platte Klasse E1 in schwarzer Farbe

④ Interne Struktur hergestellt aus Melaminplatten Klasse E1, W100 anthrazitgrau

⑤ Schubladen aus lackiertem Metall und Glas, Soft-Schließsystem

⑥ Wandmontage mit einstellbaren Wandhalterungen, Strukturstangen aus Aluminium, die als Anti-Release-System verwendet werden können.

## ② MUEBLES

Hecho con diferentes materiales, naturales o tecnológicos.

Estructura hecha con paneles de melamina Clase E1, de chapa de madera, W100, o con paneles de MDF pintados Clase E1.

③ Frentes con apertura a gola con corte de 45° hechos de:

- Acabados lacados con panel MDF Clase E1

- Acabados de madera con chapa de madera real

- Acabado de madera Jazz con chapa de madera real sobre panel MDF clase E1 en color negro

④ Estructura interna hecha con paneles de melamina Clase E1, W100 gris antracita

⑤ Cajones en metal pintado y vidrio, sistema de cierre soft-system

⑥ Instalación de pared con soportes de pared ajustables, barras estructurales en aluminio que pueden usarse como sistema antidesbloqueo.

# MET colonna: com'è realizzata

MET Hochschrank: wie er gemacht ist

MET column: cómo está hecho

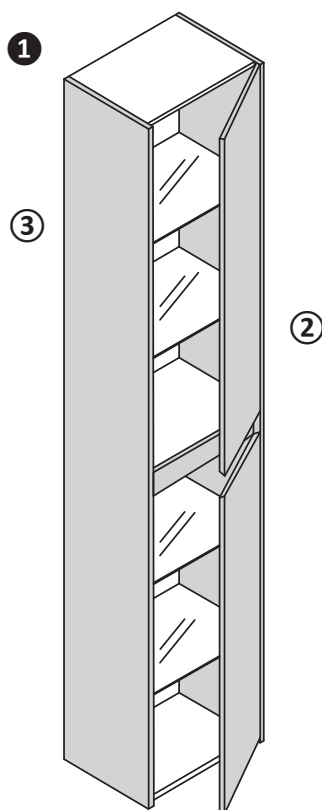

## ① Colonna

Realizzato con differenti materiali, naturali o tecnologici.

Struttura realizzata con pannelli in melamminico Classe E1, W100 impiallacciato legno, oppure con pannelli MDF Classe E1 verniciati,

③ Frontali con apertura a gola sagomata con taglio a 45° realizzati in:

- Finiture laccate con pannello in MDF Classe E1
- Finiture legno con impiallacciatura di vero legno
- Finiture legno Jazz con impiallacciatura di vero legno su pannello in MDF Classe E1 colore nero

## ② MÖBEL

Hergestellt mit verschiedenen Materialien, sowohl natürlich als auch technologisch.

Struktur aus Melaminplatten E1-Klasse, W100 Holz furnierplatten oder aus lackierten E1-Klasse MDF-Platten.

③ Fronten mit geformter Griffmulde mit 45° -Schnitt, hergestellt aus:

- Lackierte Endfertigung mit MDF-Platten der Klasse E1
- Holz ausführung mit Echtholz furnier
- Jazz-Holz ausführung mit Echtholz furnier auf MDF-Platte Klasse E1 in schwarzer Farbe

## ② MUEBLES

Hecho con diferentes materiales, naturales o tecnológicos.

Estructura hecha con paneles de melamina Clase E1, de chapa de madera, W100, o con paneles de MDF pintados Clase E1.

③ Frentes con apertura a gola con corte de 45° hechos de:

- Acabados lacados con panel MDF Clase E1
- Acabados de madera con chapa de madera real
- Acabado de madera Jazz con chapa de madera real sobre panel MDF clase E1 en color negro

# Met: materiali e finiture

Met: Materialien und Endfertigungen

Met: materiales y acabados

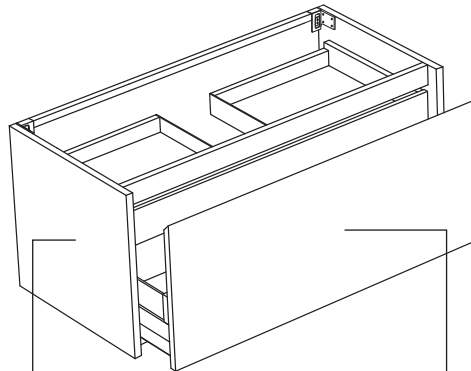

STRUTTURA  
KORPUS  
ESTRUCTURA

CAT. O - LACCATO OPACO  
CAT. B - LACCATO LUCIDO  
CAT. RN - ROVERE NATURALE  
CAT. OS - OLMO SMOKE  
CAT. WN - WALNUT NATURALE

FRONTALE  
FRONT  
FRONTAL

CAT. O - LACCATO OPACO  
CAT. B - LACCATO LUCIDO  
CAT. RN - ROVERE NATURALE  
CAT. OS - OLMO SMOKE  
CAT. JWN - WALNUT NATURALE JAZZ  
CAT. JRN - ROVERE NATURALE JAZZ  
CAT. LV2 - ROVERE VINTAGE SPACCO NERO  
CAT. W5 - ROVERE TERMO-TRATTATO

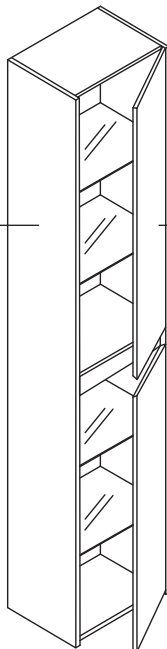

Attenzione: il legno è un prodotto naturale; pertanto l'azienda non può garantire la corrispondenza con i campioni. Qualsiasi variazione del colore, venatura o effetto del legno deve considerarsi non contestabile, rappresentando pregio del materiale e delle lavorazioni artigianali.

Achtung: Holz ist ein Naturprodukt, deshalb kann das Unternehmen nicht die Übereinstimmung mit den Mustern garantieren. Jede Abweichung in der Farbe, Maserung oder im Effekt des Holzes muss als nicht beanstandbar angesehen werden, da es ein Zeichen des Werts des Materials und der handwerklichen Verarbeitung darstellt.

Atención: la madera es un producto natural; por tanto la empresa no puede garantizar la correspondencia con las muestras. Todas variaciones del color, venas o efectos de la madera no pueden ser cuestionados, ya que representan el valor del material y de los trabajos artesanales.

# Struttura: materiali e finiture

Korpus: Materialien und Endfertigungen

Estructura: materiales y acabados

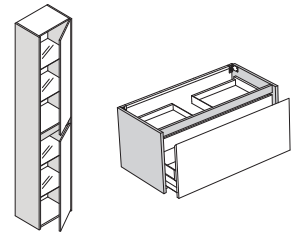

## LACCATO / LACKIERT / LACADO

**CAT. O** - Laccato opaco / Matt lackiert / Lacado mate

**CAT. B** - Laccato lucido / Glänzend lackiert / Lacado brillante

### PoppingTrend



O. 283 - B. 282  
Salice



O. 281 - B. 280  
Savana



O. 36 - B. 113  
Bordeaux



O. 285 - B. 284  
Oriente



O. 287 - B. 286  
Oceano



O. 190 - B. 189  
Oltremare

### FeelingSoft



O. 182 - B. 181  
Salvia



O. 271 - B. 270  
Tahiti



O. 273 - B. 272  
Santorini



O. 275 - B. 274  
Lavanda



O. 277 - B. 276  
Lilla



O. 279 - B. 278  
Pesca

### ForeverChic

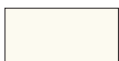

O. 20 - B. 21  
Bianco

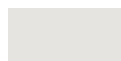

O. 231 - B. 230  
Perla



O. 233 - B. 232  
Seta

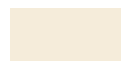

O. 235 - B. 234  
Alpaca



O. 172 - B. 171  
Lino



O. 180 - B. 179  
Avana



O. 237 - B. 236  
Argilla



O. 174 - B. 173  
Corda



O. 239 - B. 238  
Pietra



O. 241 - B. 240  
Cervino



O. 243 - B. 242  
Dolomiti



O. 245 - B. 244  
Arizona



O. 247 - B. 246  
Cipria



O. 249 - B. 248  
Erica



O. 251 - B. 250  
Terra



O. 253 - B. 252  
Granata



O. 255 - B. 254  
Bosco



O. 257 - B. 256  
Oliva



O. 259 - B. 258  
Canapa



O. 261 - B. 260  
Cotone



O. 263 - B. 262  
Efeso



O. 265 - B. 264  
Lavaredo



O. 267 - B. 266  
Pamir



O. 269 - B. 268  
Bromo



O. 198 - B. 104  
Grafite



O. 46 - B. 100  
Nero

### FenixLike



O. 289 - B. 288  
Ottawa



O. 291 - B. 290  
Londra



O. 263 - B. 262  
Efeso



O. 269 - B. 268  
Bromo



O. 295 - B. 294  
Jaipur



O. 297 - B. 296  
Orinoco



O. 293 - B. 292  
Fes

## LEGNO / HOLZ / MADERA

Venatura verticale / Senkrechte Maserung / Grano vertical

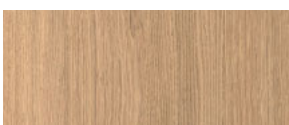

**CAT. RN**

Legno Rovere naturale



**CAT. OS**

Legno Olmo Smoke



**CAT. WN**

Legno Walnut naturale

# Frontali: materiali e finiture

Fronten: Materialien und Endfertigungen

Frontales: materiales y acabados

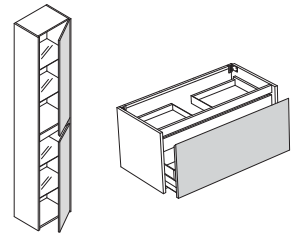

## LACCATO / LACKIERT / LACADO

**CAT. O** - Laccato opaco / Matt lackiert / Lacado mate

**CAT. B** - Laccato lucido / Glänzend lackiert / Lacado brillante

### PoppingTrend



O. 283 - B. 282  
Salice



O. 281 - B. 280  
Savana



O. 36 - B. 113  
Bordeaux



O. 285 - B. 284  
Oriente



O. 287 - B. 286  
Oceano



O. 190 - B. 189  
Oltremare

### FeelingSoft



O. 182 - B. 181  
Salvia



O. 271 - B. 270  
Tahiti



O. 273 - B. 272  
Santorini



O. 275 - B. 274  
Lavanda



O. 277 - B. 276  
Lilla



O. 279 - B. 278  
Pesca

### ForeverChic



O. 20 - B. 21  
Bianco

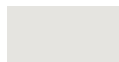

O. 231 - B. 230  
Perla



O. 233 - B. 232  
Seta

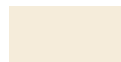

O. 235 - B. 234  
Alpaca



O. 172 - B. 171  
Lino



O. 180 - B. 179  
Avana



O. 237 - B. 236  
Argilla



O. 174 - B. 173  
Corda



O. 239 - B. 238  
Pietra



O. 241 - B. 240  
Cervino



O. 243 - B. 242  
Dolomiti



O. 245 - B. 244  
Arizona



O. 247 - B. 246  
Cipria



O. 249 - B. 248  
Erica



O. 251 - B. 250  
Terra



O. 253 - B. 252  
Granata



O. 255 - B. 254  
Bosco



O. 257 - B. 256  
Oliva



O. 259 - B. 258  
Canapa



O. 261 - B. 260  
Cotone



O. 263 - B. 262  
Efeso



O. 265 - B. 264  
Lavaredo



O. 267 - B. 266  
Pamir



O. 269 - B. 268  
Bromo



O. 198 - B. 104  
Grafite



O. 46 - B. 100  
Nero

### FenixLike



O. 289 - B. 288  
Ottawa



O. 291 - B. 290  
Londra



O. 263 - B. 262  
Efeso



O. 269 - B. 268  
Bromo



O. 295 - B. 294  
Jaipur



O. 297 - B. 296  
Orinoco



O. 293 - B. 292  
Fes

# Frontali: materiali e finiture

Fronten: Materialien und Endfertigungen

Frontales: materiales y acabados

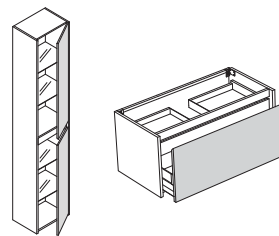

## LEGNO JAZZ / HOLZ JAZZ / MADERA JAZZ

Venatura verticale / Senkrechte Maserung / Grano vertical



### **CAT. JRN**

Legno Rovere naturale Jazz

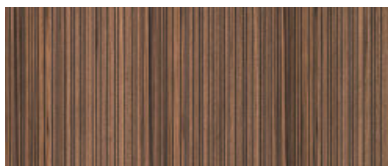

### **CAT. JWN**

Legno Walnut Jazz

## LEGNO / HOLZ / MADERA

Venatura verticale / Senkrechte Maserung / Grano vertical

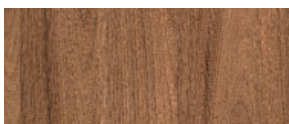

### **CAT. OS**

Legno Olmo Smoke

Venatura orizzontale / Waagerechte Maserung / Grano horizontal



### **CAT. RN**

Legno Rovere naturale



### **CAT. LV2**

Legno Rovere Vintage  
con spacco nero



### **CAT. W5**

Legno Rovere  
termo-trattato

# Met: panoramica prodotti

Met: Produktübersicht

Met: visión general del producto

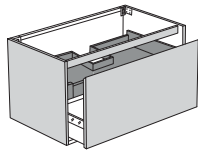

H.48

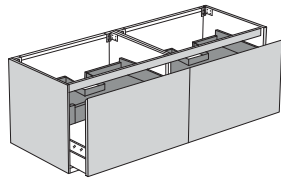

H.48

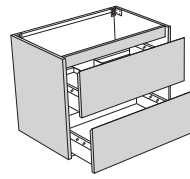

H.55

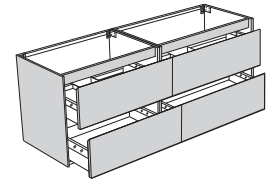

H.55

	H.48	H.48	H.55	H.55
L.70				
L.80				
L.90				
L.100				
L.120	  		  	
L.140		  		  
L.160		  		  
L.180		  		  