



Gola Design

meubles | meubels | base units

P 51,5 cm



Gola Design : en détail

Gola Design: hoe wordt het gemaakt

Gola Design: how it is made

Gola Design meuble

Gola Design meubel

Gola Design base unit

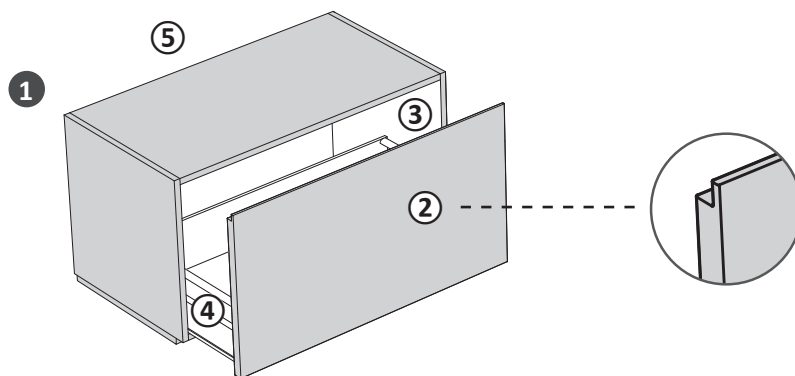

Gola Design : meubles sous-vasques

Gola Design: onderkasten voor wastafels

Gola Design: washbasin base units

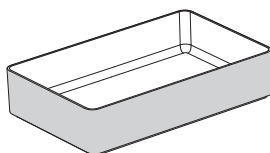

Vasque à poser
Opbouwwastafel
Sit-on washbasin

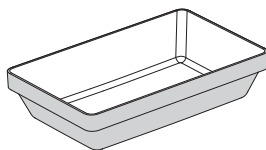

Vasque à poser semi-encastée
Half-ingebouwde opbouwwastafel
Semi-recessed sit-on washbasin

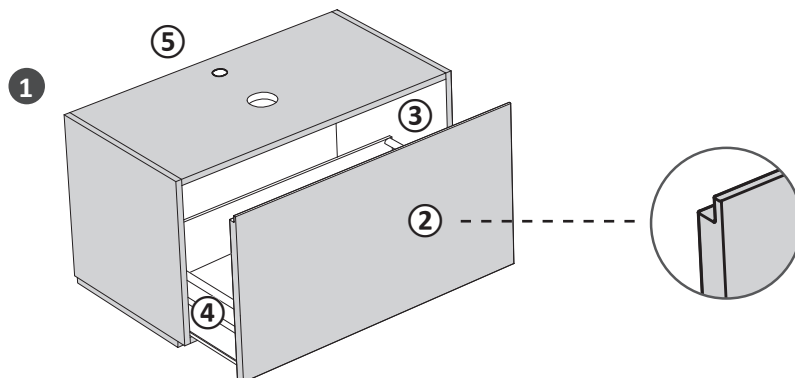

Gola Design : en détail

Gola Design: hoe wordt het gemaakt

Gola Design: how it is made

Gola Design

Les meubles avec ouverture Gola Design sont disponibles suspendus ou au sol, dans les finitions O, B. Également disponible dans la version sous-vasque pour vasques à poser ou semi-encastrées

① MEUBLE

Côtés réalisés avec panneaux de mélamine Classe E1, W100, intérieur gris anthracite, laquées extérieurement et sur les bords

② Façades avec ouverture à gorge, réalisées en finition laquée avec panneau MDF Classe E1

③ Structure interne réalisée avec des panneaux de mélamine Classe E1, W100 gris anthracite

④ Tiroirs en métal verni, fermeture "soft-system"

⑤ Installation murale avec supports muraux réglables, barres structurelles en aluminium équipées d'un système anti-dégagement.

Gola Design

De meubels met een openingsstelsel Gola Design zijn verkrijgbaar ofwel in de hangende versie, ofwel staand, in de afwerkingen O, B. Ook verkrijgbaar in de versie onderkast voor een bovenop geplaatste of half-ingebouwde wastafel.

① KAST

Zijpanelen met melaminelaag klasse E1, inwendig antracietgrijs W100, gelakte buitenkant en randen

② Frontelementen met verzonken profielgreep, gelakte afwerkingen, met MDF-paneel klasse E1

③ Inwendige structuur met panelen met melaminelaag klasse E1, antracietgrijs W100

④ Laden van gelakt metaal, zachtsluitend

⑤ Bevestiging aan de wand met verstelbaar wandbeslag, aluminium wandrails met kantelbeveiliging.

Gola Design

The base units with Gola Design opening are available suspended or on the ground in the finishes O, B. Also available in the washbasin version for sit-on or semi-recessed washbasins.

① BASE UNIT

Sides made with melamine Class E1, W100 panels, anthracite gray interior, lacquered externally and on the edges

② Fronts with groove opening, in the laquered finishes, made with MDF panels Class E1

③ Internal structure made with melamine panels Class E1, W100 anthracite gray

④ Painted metal drawers, soft-closing system

⑤ Wall installation with adjustable wall brackets, structural bars in aluminium equipped with an anti-release system.

Réalisations sur mesure

Op maat gemaakte bewerkingen

Made-to-measure

Meubles

- Pour toute modification demander la faisabilité et les devis au bureau commercial à l'adresse email commerciale@stocco.it.
- Couleurs RAL ou à échantillon : supplément de €350 par composition.

Meubels

- Voor iedere aanpassing moet de uitvoerbaarheid en de prijs ervan bij de commerciële dienst nagevraagd worden op het e-mailadres commerciale@stocco.it.
- Ral-kleuren ofwel per kleurstaal, meerprijs van €350 per samenstelling.

Base units

- For every modification request feasibility and offer to the sales office at the email address commerciale@stocco.it.
- Ral or sample colors: supplement of €350 per composition.

Gola Design : matériaux et finitions

Gola Design: materialen en afwerkingen

Gola Design: materials and finishes

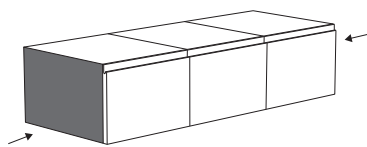
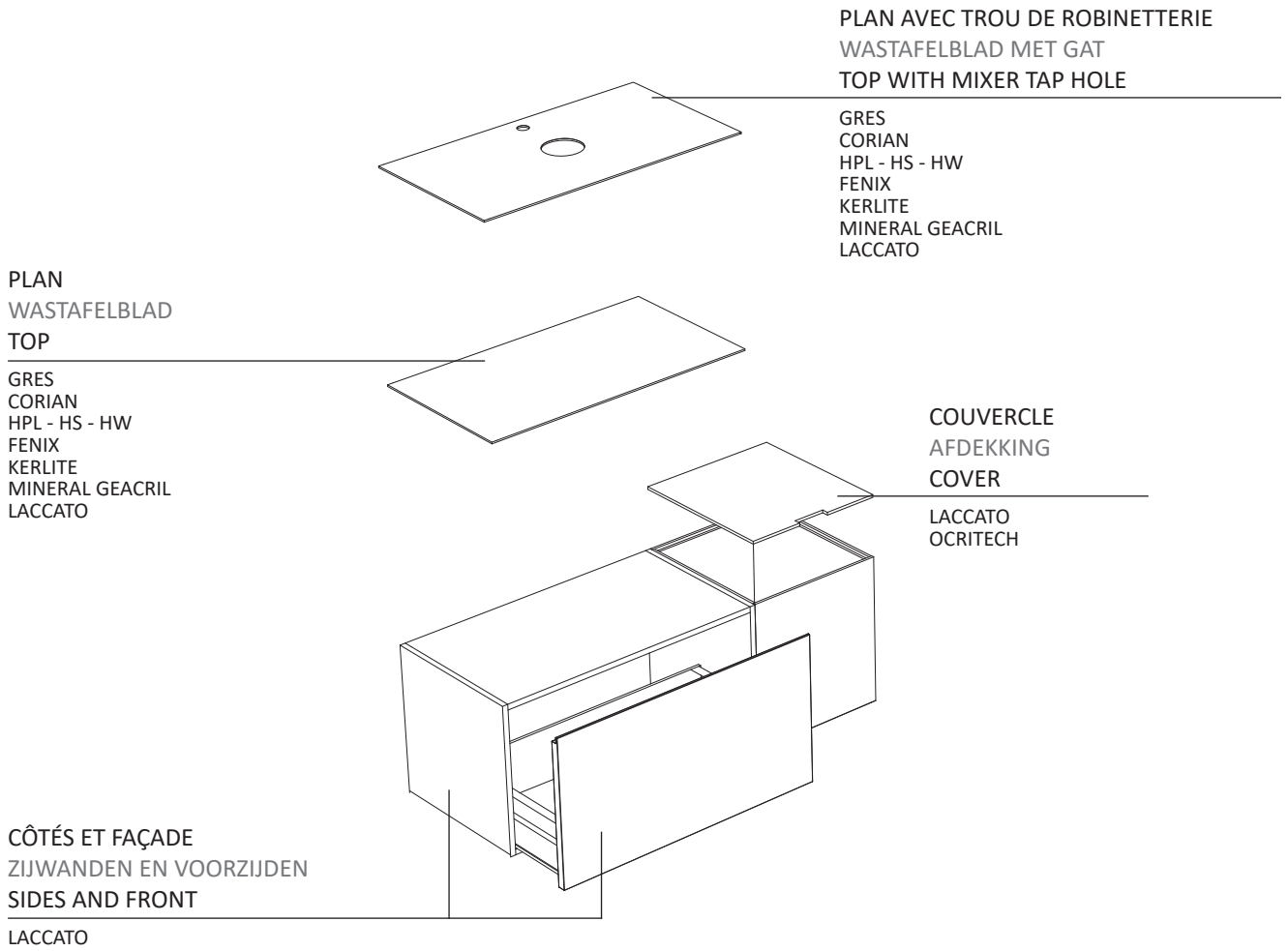

Attention : dans les compositions sont laqués seulement les cotés extérieur visibles, voir les figures

Opgepast: in de samenstellingen zijn enkel de buitenste, zichtbare zijwanden gelakt, zie figuren

Attention: only the visible sides are lacquered in the compositions, see figures

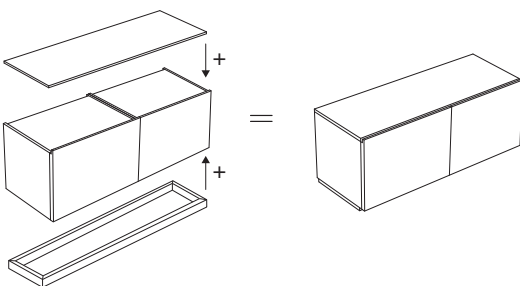

Attention : commander toujours le plan de finition des meubles; commander le socle pour les meuble au sol

Opgepast: altijd het afdeklad en de plint van de meubels bestellen

Attention: always order the finishing top for the units; order the socle for standing unit

Côtés et façades, plan : matériaux et finitions

Zijkanten en fronten, Wastafelblad: Materialen en afwerkingen

Sides and fronts, top: Materials and finishes

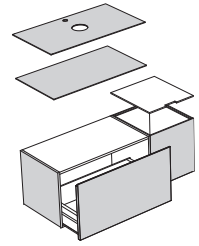

LAQUÉ / GELAKT / LACQUERED

CAT. O - Laqué mat / Mat gelakt / Matt lacquered

CAT. B - Laqué brillant / Glanzend gelakt / Glossy lacquered

PoppingTrend



O. 283 - B. 282
Salice



O. 281 - B. 280
Savana



O. 36 - B. 113
Bordeaux



O. 285 - B. 284
Oriente



O. 287 - B. 286
Oceano



O. 190 - B. 189
Oltremare

FeelingSoft



O. 182 - B. 181
Salvia



O. 271 - B. 270
Tahiti



O. 273 - B. 272
Santorini



O. 275 - B. 274
Lavanda



O. 277 - B. 276
Lilla



O. 279 - B. 278
Pesca

ForeverChic



O. 20 - B. 21
Bianco

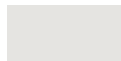

O. 231 - B. 230
Perla



O. 233 - B. 232
Seta

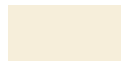

O. 235 - B. 234
Alpaca



O. 172 - B. 171
Lino



O. 180 - B. 179
Avana



O. 237 - B. 236
Argilla



O. 174 - B. 173
Corda



O. 239 - B. 238
Pietra



O. 241 - B. 240
Cervino



O. 243 - B. 242
Dolomiti



O. 245 - B. 244
Arizona



O. 247 - B. 246
Cipria



O. 249 - B. 248
Erica



O. 251 - B. 250
Terra



O. 253 - B. 252
Granata



O. 255 - B. 254
Bosco



O. 257 - B. 256
Oliva



O. 259 - B. 258
Canapa



O. 261 - B. 260
Cotone



O. 263 - B. 262
Efeso



O. 265 - B. 264
Lavaredo



O. 267 - B. 266
Pamir



O. 269 - B. 268
Bromo



O. 198 - B. 104
Grafite



O. 46 - B. 100
Nero

FenixLike



O. 289 - B. 288
Ottawa



O. 291 - B. 290
Londra



O. 263 - B. 262
Efeso



O. 269 - B. 268
Bromo



O. 295 - B. 294
Jaipur



O. 297 - B. 296
Orinoco



O. 293 - B. 292
Fes

Plan : matériaux et finitions

Wastafelblad: materialen en afwerkingen

Top: materials and finishes

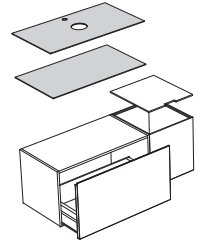

CORIAN®



CAT. CO

Corian Bianco opaco

MINERAL GEACRIL



CAT. MGO

Mineral Geacril Bianco opaco



CAT. MGL

Mineral Geacril Bianco lucido

CAT. MGC

Mineral Geacril colorato opaco

PoppingTrend



O. 283
Salice



O. 281
Savana



O. 36
Bordeaux



O. 285
Oriente



O. 287
Oceano



O. 190
Oltremare

FeelingSoft



O. 182
Salvia



O. 271
Tahiti



O. 273
Santorini



O. 275
Lavanda



O. 277
Lilla



O. 279
Pesca

ForeverChic



O. 20
Bianco

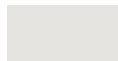

O. 231
Perla



O. 233
Seta

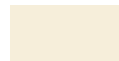

O. 235
Alpaca



O. 172
Lino



O. 180
Avana



O. 237
Argilla



O. 174
Corda



O. 239
Pietra



O. 241
Cervino



O. 243
Dolomiti



O. 245
Arizona



O. 247
Cipria



O. 249
Erica



O. 251
Terra



O. 253
Granata



O. 255
Bosco



O. 257
Oliva



O. 259
Canapa



O. 261
Cotone



O. 263
Efeso



O. 265
Lavaredo



O. 267
Pamir



O. 269
Bromo



O. 198
Grafite



O. 46
Nero

FenixLike



O. 289
Ottawa



O. 291
Londra



O. 263
Efeso



O. 269
Bromo



O. 295
Jaipur



O. 297
Orinoco



O. 293
Fes

Plan : matériaux et finitions

Wastafelblad: materialen en afwerkingen

Top: materials and finishes

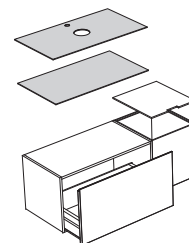

GRES

CAT. FG



Gres mat / Gres mat / Gres matt

FG01
Bianco Statuario Venato
opaco



FG03
Oro Venato opaco



FG05
Nero Marquina opaco

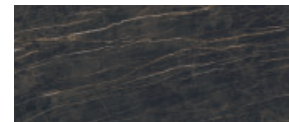

FG07
Noir Desir opaco

Gres brillant / Gres glanzend / Gres glossy

FG02
Bianco Statuario Venato
lucidato

FG04
Oro Venato lucidato

FG06
Nero Marquina lucidato

FG08
Noir Desir lucidato

KERLITE®

CAT. METAL KERLITE



KM01
Metal Corten nat.

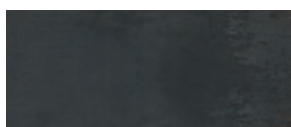

KM02
Metal Iron nat.

CAT. A KERLITE



KE01
Road nat.

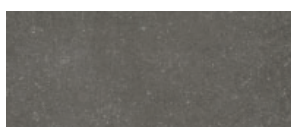

KE05
Cendre nat.

Plan : matériaux et finitions

Wastafelblad: materialen en afwerkingen

Top: materials and finishes

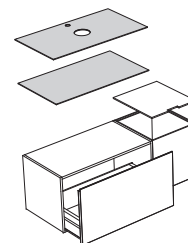

HPL

CAT. HPL



B533
White Wood



B534
Olmo



B507
Grigio Chiaro

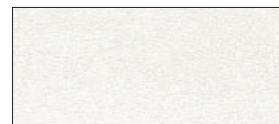

B539
Bianco Dax Stone



B508
Portland



B546
Ossido

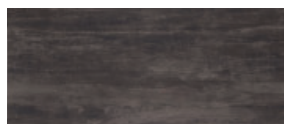

B500
Fossile



B545
Cesar Brown Stone

CAT. HS

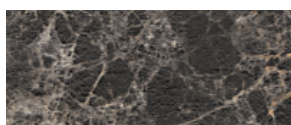

HS563
Emperador



HS424
Calacatta

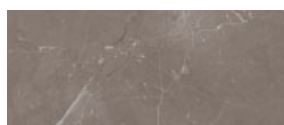

HS555
Botticino



HS547
Travertino

CAT. HW



HW587
Rovere Slavonia



HW669
Rovere Primitivo

FENIX®

CAT. AF - FENIX

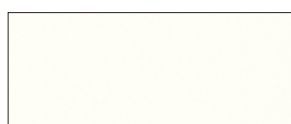

FX32
Bianco Kos



FX720
Nero Ingo

CAT. BF - FENIX COLORATO



FX717
Castoro Ottawa



FX718
Grigio Londra



FX725
Grigio Efeso



FX724
Grigio Bromo



FX751
Rosso Jaipur



FX749
Cacao Orinoco



FX754
Blu Fes

Attention : l'épaisseur du plan diffère selon les matériaux

Opgepast: de dikte van het wastafelblad verschilt al naargelang het materiaal

Attention: the thickness of the top differs according to the material

Couvercle : matériaux et finitions

Afdekking: materialen en afwerkingen

Cover: materials and finishes

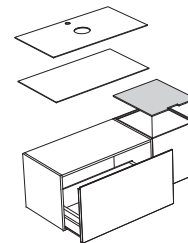

LAQUÉ / GELAKT / LACQUERED

CAT. O - Laqué mat / Mat gelakt / Matt lacquered

CAT. B - Laqué brillant / Glanzend gelakt / Glossy lacquered

PoppingTrend



O. 283 - B. 282
Salice



O. 281 - B. 280
Savana



O. 36 - B. 113
Bordeaux



O. 285 - B. 284
Oriente



O. 287 - B. 286
Oceano



O. 190 - B. 189
Oltremare

FeelingSoft



O. 182 - B. 181
Salvia



O. 271 - B. 270
Tahiti



O. 273 - B. 272
Santorini



O. 275 - B. 274
Lavanda



O. 277 - B. 276
Lilla



O. 279 - B. 278
Pesca

ForeverChic



O. 20 - B. 21
Bianco

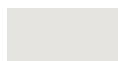

O. 231 - B. 230
Perla



O. 233 - B. 232
Seta

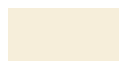

O. 235 - B. 234
Alpaca



O. 172 - B. 171
Lino



O. 180 - B. 179
Avana



O. 237 - B. 236
Argilla



O. 174 - B. 173
Corda



O. 239 - B. 238
Pietra



O. 241 - B. 240
Cervino



O. 243 - B. 242
Dolomiti



O. 245 - B. 244
Arizona



O. 247 - B. 246
Cipria



O. 249 - B. 248
Erica



O. 251 - B. 250
Terra



O. 253 - B. 252
Granata



O. 255 - B. 254
Bosco



O. 257 - B. 256
Oliva



O. 259 - B. 258
Canapa



O. 261 - B. 260
Cotone



O. 263 - B. 262
Efeso



O. 265 - B. 264
Lavaredo



O. 267 - B. 266
Pamir



O. 269 - B. 268
Bromo



O. 198 - B. 104
Grafite



O. 46 - B. 100
Nero

FenixLike



O. 289 - B. 288
Ottawa



O. 291 - B. 290
Londra



O. 263 - B. 262
Efeso



O. 269 - B. 268
Bromo



O. 295 - B. 294
Jaipur



O. 297 - B. 296
Orinoco



O. 293 - B. 292
Fes

OCRITECH®



CAT. OCR

Ocritch Bianco opaco

Gola Design : vue d'ensemble de la collection

Gola Design: overzicht produkten

Gola Design: product overview

Sous-vasques

Onderkasten wastafelmeubels

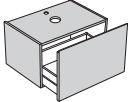
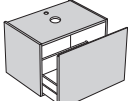
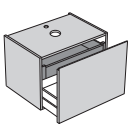

Washbasin base units

		L.45	L.60	L.70	L.80	L.90	L.120
H.32		●	●	●	●	●	●
H.48		●	●	●	●	●	●
H.48		●	●	●	●	●	●

Meubles bas

Meubels

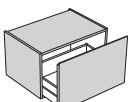
Base units

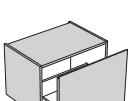
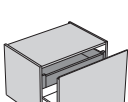
		L.45	L.60	L.70	L.80	L.90	L.120
H.32		●					
H.32		●	●	●	●	●	●
H.48		●					
H.48		●	●	●	●	●	●
H.48		●	●	●	●	●	●

● Disponible | Beschikbaar | Available

Mineral Geacril

Mineral Geacril est un matériau composite constitué de charges minérales naturelles et de résine polyester, recouvert d'un film de surface élégant et agréable au toucher (gelcoat), aux propriétés antibactériennes, ignifuges et auto-extinguibles. Mineral Geacril a une excellente résistance chimique-physique, est durable dans le temps, hygiénique et facile à entretenir. Disponible en finition brillante ou mate en version blanche ou colorée.

Mineral Deimos est un matériau composite massif et non poreux constitué d'une combinaison de minéraux naturels et de résines polyester/acrylique de la plus haute qualité. La surface est compacte, hygiénique, ignifuge, antibactérienne.

Entretien et nettoyage

Nettoyer avec un chiffon doux ou une éponge humide non abrasive en utilisant des détergents neutres non abrasifs. A la fin de l'opération de nettoyage, bien rincer la surface. Ne pas utiliser de solvants chimiques agressifs tels que l'acétone, le trichloréthylène et autres solvants. Les cosmétiques et les teintures peuvent libérer des colorants et, par conséquent, nous vous recommandons d'éviter qu'ils n'entrent en contact avec la surface.

Les surfaces colorées sont protégées par un traitement hydrofuge et oléofuge qui les rend plus résistantes aux rayures et aux traces de doigts. Malgré cela, ils nécessitent plus d'attention à l'utilisation car tout dommage ou rayure est plus perceptible. Nous recommandons de sécher la surface avec un chiffon doux ou du papier absorbant pour éviter les dépôts d'eau ou de calcaire.



Hygiénique
Hygiënisch
Hygienic

Mineral Geacril is een composiet materiaal dat uit natuurlijke mineralen en polyester bestaat met een elegante en aangenaam aanvoelende gelcoat en antibacteriële, vuurbestendige en zelfdovende eigenschappen. Mineral Geacril heeft een uitstekende chemische en fysieke weerstand, is duurzaam en onderhoudsvriendelijk. Het is beschikbaar met een hoogglanzende afwerking of een mat witte of gekleurde afwerking.

Mineral Deimos is een niet poreus massief composiet materiaal dat bestaat uit een combinatie van natuurlijke mineralen en polyester/acrylhars van hoge kwaliteit. Het oppervlak is compact, zuiver, brandvast en antibacterieel.

Onderhoud en schoonmaken

Schoonmaken met een vochtige zachte doek of spons en neutrale, zachte reinigingsproducten. Na het schoonmaken goed afspoelen. Geen bijtende chemische middelen gebruiken zoals aceton, trichlooretheen of andere oplosmiddelen. Cosmetische producten en verf kunnen kleurstoffen vrijgeven, dus raden wij aan om contact ervan met dit materiaal te vermijden.

De gekleurde oppervlakken zijn beschermd met een water- en olieafstotende behandeling die het materiaal ook beter bestand maakt tegen krassen en vlekken. Desondanks vergen ze tijdens het gebruik meer aandacht omdat elke kras of beschadiging zichtbaar is. Wij raden aan om dit materiaal droog te wrijven met een zachte doek of keukenpapier om geen vocht of kalk achter te laten.

Mineral Geacril is a composite material consisting of natural mineral fillers and polyester resin, coated with an elegant and pleasant to the touch surface film (gelcoat), with antibacterial, flame retardant and self-extinguishing properties. Mineral Geacril has excellent chemical-physical resistance, is durable over time, hygienic and easy to maintain. Available in bright glossy finish, or matt in white or colored version.

Mineral Deimos is a massive, non-porous composite material made up of a combination of natural minerals and polyester / acrylic resins of the highest quality. The surface is compact, hygienic, fireproof, antibacterial.

Maintenance and cleaning

Clean with a soft cloth or a damp non-abrasive sponge using neutral non-abrasive detergents. At the end of the cleaning operation, rinse the surface well. Do not use aggressive chemical solvents such as acetone, trichlorethylene and other solvents. Cosmetics and dyes can release color and, therefore, we recommend avoiding that they come into contact with the surface.

The colored surfaces are protected by a water and oil repellent treatment which makes them more resistant to scratches and fingerprints. Despite this, they need more attention in use because any damage or scratch is more perceptible. We recommend drying the surface with a soft cloth or absorbent paper to avoid water or limescale deposits.



Facile à nettoyer
Gemakkelijk schoon te maken
Easy to clean

Ocritech® est une solid surface de dernière génération, acrylique, sans charges minérales. Parmi ses caractéristiques se distinguent son excellente résistance aux chocs, aux intempéries et au vieillissement; il ne change pas des couleurs et ne jaunit pas. Ocritech® a une bonne résistance aux rayures et peut être restauré. En outre, il offre une bonne résistance aux substances acides et à l'absorption des produits cosmétiques.

Entretien et nettoyage

Nettoyer avec un chiffon doux ou une éponge non abrasive et des détergents neutres, non abrasifs ou légèrement abrasifs. Bien rincer la surface après le nettoyage. Ne pas utiliser de solvants chimiques agressifs comme l'acétone, le trichloréthylène et les solvants. Les cosmétiques et les teintures peuvent libérer des colorants, c'est pourquoi nous recommandons d'éviter tout contact avec la surface.

Ocritech® is een Solid Surface van de laatste generatie, acryl gebonden, zonder mineralen. Één van de kenmerken is een uitstekende bestendigheid tegen stoten, weersomstandigheden en veroudering; de kleur vervaalt en vergeelt niet. Ocritech® heeft een goede krasbestendigheid en kan hersteld worden. Bovendien weerstaat het goed aan zure stoffen en aan cosmetica.

Onderhoud en schoonmaak

Schoonmaken met een niet-schurende vochtige doek of spons met neutrale poetsmiddelen, niet schurende ofwel licht schurende. Na het schoonmaken de oppervlakte goed naspoelen. Geen agressieve chemische solventen gebruiken zoals aceton, trichloorethyleen en solventen. Make-up en haarverf kunnen kleurstoffen afgeven en we raden dan ook aan ervoor te zorgen dat deze niet in contact komen met de oppervlakte.

Ocritech® is a latest generation solid surface, acrylic, without mineral fillers. Among its features stands out its excellent resistance to impact, weathering and aging; it does not turn shades and does not yellow. Ocritech® has a good scratch resistance and can be restored. Furthermore, it offers good resistance to acidic substances and the absorption of cosmetic products.

Maintenance and cleaning

Clean with a soft cloth or humid non-abrasive sponge using neutral and non-abrasive (or slightly abrasive) detergents. Rinse the surface carefully after cleaning. Do not use aggressive chemical solvents, such as acetone and trichloroethylene. Cosmetics and dyes may release colourants; therefore, we recommend preventing them from contacting the surface.



Hygiénique
Hygiënisch
Hygienic



Facile à nettoyer
Gemakkelijk schoon te maken
Easy to clean



Résistant aux éraflures
Krasbestendig
Scratch-resistant

Corian®

CORIAN® est un matériau innovant au toucher soyeux à multiples utilisations. Il est fabriqué à base de minéraux naturels et de polymères acryliques purs. Les produits en CORIAN® sont obtenus par thermoformation permettant de réaliser des formes douces ou par la technique de l'encollage à joints invisibles pour créer des formes plus carrées. La surface est mate, très compacte, soyeuse, très résistante aux éraflures et à la moisissure, et peut être restaurée.

Entretien et nettoyage

Nettoyer avec un chiffon doux ou une éponge non abrasive et des détergents neutres, non abrasifs ou légèrement abrasifs. Bien rincer la surface après le nettoyage. Ne pas utiliser de solvants chimiques agressifs comme l'acétone, le trichloréthylène et les solvants. Les cosmétiques et les teintures peuvent libérer des colorants, c'est pourquoi nous recommandons d'éviter tout contact avec la surface.

CORIAN® is een vernieuwend en zeer veelzijdig materiaal met een kenmerkend zijdeachtig effect. Het is samengesteld uit natuurlijke geladen mineralen en uit zuivere acrylpolymere. De producten in CORIAN® worden gemaakt via termovorming om afgeronde vormen te verkrijgen, ofwel gelijmd zonder naden om de hoekige vormen te bekomen. De oppervlakte is mat, heel compact, zijdeachtig, zeer krasbestendig, anti-schimmel en herstelbaar.

Onderhoud en schoonmaak

Schoonmaken met een niet-schurende vochtige doek of spons met neutrale poetsmiddelen, niet schurende ofwel licht schurende. Na het schoonmaken de oppervlakte goed naspoelen. Geen agressieve chemische solventen gebruiken zoals aceton, trichloorethyleen en solventen. Make-up en haarverf kunnen kleurstoffen afgeven en we raden dan ook aan ervoor te zorgen dat deze niet in contact komen met de oppervlakte.

CORIAN® is an innovative and highly versatile material that has a typical silky effect. It is made of natural mineral charges and pure acrylic polymers. CORIAN® products are made either by thermoforming to produce soft shapes, or by a gluing technique with invisible seams to produce square shapes. Its surface is opaque, very compact, silky, resistant to scratches, to mould and can be restored.

Maintenance and cleaning

Clean with a soft cloth or humid non-abrasive sponge using neutral and non-abrasive (or slightly abrasive) detergents. Rinse the surface carefully after cleaning. Do not use aggressive chemical solvents, such as acetone and trichloroethylene. Cosmetics and dyes may release colourants; therefore, we recommend preventing them from contacting the surface.



Hygiénique
Hygiënisch
Hygienic



Facile à nettoyer
Gemakkelijk schoon te maken
Easy to clean



Résistant aux éraflures
Krasbestendig
Scratch-resistant

Kerlite®

Kerlite® est une céramique porcelainée ultra-mince de qualité supérieure, de conception nouvelle dont les points forts sont l'adaptabilité et la facilité d'emploi. Il est résistant tout en étant léger, plat mais souple et facile à désinfecter, totalement écologique et à même d'atteindre l'excellence des carreaux de grès céramique.

Entretien et nettoyage

Nettoyer avec un chiffon ou une éponge humide et des détergents neutres non abrasifs, dilués dans l'eau chaude. Bien rincer la surface après le nettoyage. Ne pas utiliser de solvants chimiques agressifs.

Kerlite® is ultradun porseleinkeramiek van superieure kwaliteit, een nieuw concept met als bijzondere kenmerken veelzijdigheid en gebruiksgemak. Het is zeer resistent maar toch licht, vlak maar tegelijk flexibel, gemakkelijk schoon te maken en volledig ecologisch; dit materiaal tilt de kwaliteit van keramische tegels naar een hoger niveau.

Onderhoud en schoonmaak

Schoonmaken met een vochtige doek of spons, met neutrale, niet-schurende poetsmiddelen, verdund in warm water. Na het schoonmaken de oppervlakte goed naspoelen. Geen agressieve chemische solventen gebruiken zoals aceton, trichloorethyleen en solventen.

Kerlite® is a high-quality, very fine ceramic porcelain. Its a new concept, extremely versatile and easy to work. It is resistant but light, flat but flexible. It can be cleaned easily, it is completely environmentally friendly and is used to make excellent quality porcelain stoneware.

Maintenance and cleaning

Clean with a cloth or humid sponge using neutral and non-abrasive detergents diluted in hot water. Rinse the surface carefully after cleaning. Do not use aggressive chemical solvents.



Hygiénique
Hygiënisch
Hygienic



Facile à nettoyer
Gemakkelijk schoon te maken
Easy to clean



Résistant aux éraflures
Krasbestendig
Scratch-resistant

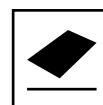

Planar et mince
Vlak en dun
Flat and thin

Gres

Le gres est une céramique porcelainée ultra-mince de qualité supérieure, de conception nouvelle dont les points forts sont l'adaptabilité et la facilité d'emploi. Il est résistant tout en étant léger, plat mais souple et facile à désinfecter, totalement écologique et à même d'atteindre l'excellence des carreaux de grès céramique.

Entretien et nettoyage

Nettoyer avec un chiffon ou une éponge humide et des détergents neutres non abrasifs, dilués dans l'eau chaude. Bien rincer la surface après le nettoyage. Ne pas utiliser de solvants chimiques agressifs.

Gres is ultradun porseleinkeramiek van superieure kwaliteit, een nieuw concept met als bijzondere kenmerken veelzijdigheid en gebruiksgemak. Het is zeer resistent maar toch licht, vlak maar tegelijk flexibel, gemakkelijk schoon te maken en volledig ecologisch; dit materiaal tilt de kwaliteit van keramische tegels naar een hoger niveau.

Onderhoud en schoonmaak

Schoonmaken met een vochtige doek of spons, met neutrale, niet-schurende poetsmiddelen, verdund in warm water. Na het schoonmaken de oppervlakte goed naspoelen. Geen agressieve chemische solventen gebruiken zoals aceton, trichloorethyleen en solventen.

Gres is a high-quality, very fine ceramic porcelain. Its a new concept, extremely versatile and easy to work. It is resistant but light, flat but flexible. It can be cleaned easily, it is completely environmentally friendly and is used to make excellent quality porcelain stoneware.

Maintenance and cleaning

Clean with a cloth or humid sponge using neutral and non-abrasive detergents diluted in hot water. Rinse the surface carefully after cleaning. Do not use aggressive chemical solvents.



Hygiénique
Hygiënisch
Hygienic



Facile à nettoyer
Gemakkelijk schoon te maken
Easy to clean



Résistant aux éraflures
Krasbestendig
Scratch-resistant

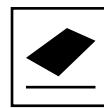

Planar et mince
Vlak en dun
Flat and thin

HPL (High Pressure Laminate)

Les stratifiés HPL (High Pressure Laminate) sont composés de couches multiples de carton imprégné de résines thermodurcissables et compactées par l'action combinée de la chaleur et de la haute pression. Le résultat est un produit stable, non réactif, homogène, non poreux et de haute densité, aux caractéristiques physiques et chimiques qui le rendent extrêmement robuste. Résistant aux éraflures, abrasions, substances chimiques et chaleur, HPL-Uicolor est idéal pour une vaste gamme d'applications de design intérieur.

Entretien et nettoyage

Nettoyer avec un chiffon doux ou une éponge non abrasive humide et des détergents neutres non abrasifs. Bien rincer la surface après le nettoyage. Ne pas utiliser de solvants chimiques agressifs comme l'acétone, le trichloréthylène, les solvants, les produits à base de cire, blanchissants ou chlorés.

De HPL-hoge druk-laminaten (High Pressure Laminate) zijn opgebouwd uit vele lagen platen, gedrenkt in thermohardende harsen, die samengeperst worden door een combinatie van warmte en sterke druk. Het resultaat is een stabiel product, niet reactief, homogeen, niet poreus en met een hoge dichtheid, met fysische en chemische eigenschappen die een lange levensduur garanderen. HPL-Uicolor laminaten zijn kras- en stootbestendig, bestand tegen chemische stoffen en warmte, en zijn de ideale oplossing voor een hele reeks toepassingen voor de binnenhuisinrichting.

Onderhoud en schoonmaak

Schoonmaken met een niet-schurende vochtige doek of spons met neutrale, niet-schurende poetsmiddelen. Na het schoonmaken de oppervlakte goed naspoelen. Geen agressieve chemische solventen gebruiken zoals aceton, trichloorethyleen, solventen, en producten die was, bleekmiddel of chloor bevatten.

The HPL (High Pressure Laminates) consist of several layers of paper permeated with thermosetting resins and compacted by the combined action of heat and high pressure. The result is a stable, non-reactive, homogeneous, non-porous and high density product, with physical and chemical features making it extremely sturdy. Resistant to scratches, blows, abrasions, chemical substances and heat, HPL-Uicolor is ideal for a wide range of interior design applications.

Maintenance and cleaning

Clean with a soft cloth or humid non-abrasive sponge using neutral and non-abrasive detergents. Rinse the surface carefully after cleaning. Do not use aggressive chemical solvents, such as acetone, trichloroethylene, solvents, wax, bleach or chlorine.



Certificat pour les panneaux en mélaminé et MDF garantissant l'emploi de panneaux à émission de formaldéhyde inférieure au minimum imposé par la norme européenne UNI EN13896.

Certificaat voor panelen in melamine en MDF ter garantie dat er panelen gebruikt worden met een formaldehyde uitstoot die lager ligt dan het wettelijk minimum van de Europese norm UNI EN13896.

Certificate for melamine and MDF panels that guarantees the use of panels with formaldehyde emissions lower than the minimum required by the European standard UNI EN13896.



Certificat de traitement du panneau à la résine hydrofuge.

Certificaat dat de panelen met waterafstotende harsen behandeld werden.

Certificate of treatment of panels with water-repellent resins.



Hygiénique
Hygiënisch
Hygienic



Facile à nettoyer
Gemakkelijk schoon te maken
Easy to clean



Résistant aux éraflures
Krasbestendig
Scratch-resistant



Écologique
Ecologisch
Ecological

Matériau innovant créé pour le design intérieur. La partie extérieure de FENIX NTM® est obtenue à l'aide de nanotechnologies et caractérisée par une surface décorative traitée par des résines thermoplastiques de nouvelle génération qui la rend extrêmement mate, en limitant la réflexion de la lumière, anti-abrasion, douce au toucher et permettant la réparation thermique des micro-éraflures. En outre, FENIX NTM® est un matériau résistant aux éraflures, au frottement, à l'abrasion et au choc, avec une capacité élevée d'élimination des bactéries, hygiénique, facile à nettoyer, anti-moisissure, antistatique, hydrofuge et résistant à la chaleur sèche.

Entretien et nettoyage

Nettoyer avec un chiffon doux ou une éponge non abrasive humide et des détergents neutres non abrasifs. Bien rincer la surface après le nettoyage. Ne pas utiliser de solvants chimiques agressifs comme l'acétone, le trichloréthylène, les solvants et les produits à base de cire, blanchissants ou chlorés. Utiliser de l'alcool ou de l'acétone et un chiffon doux pour retirer les taches rebelles.

Een vernieuwend materiaal, speciaal gecreëerd voor de binnenhuisinrichting. De buitenkant van FENIX NTM® wordt gemaakt met behulp van nanotechnologieën en wordt gekenmerkt door een gedecoreerd oppervlak, dat behandeld is met de nieuwste generatie thermoplastische harsen die de oppervlakte zeer mat maken, met een beperkte lichtweerkaatsing, zodat het bestand is tegen vingerafdrukken, zacht aanvoelt en de mogelijkheid biedt kleine krassen via verhitting weg te werken. Bovendien is FENIX NTM® een krasbestendig materiaal, dat tegen wrijving kan, stootvast is en een grote antibacteriële werking heeft, hygiënisch is, gemakkelijk in onderhoud, anti-schimmel, anti-statisch, waterafstotend, en dat bestand is tegen droge hitte.

Onderhoud en schoonmaak

Schoonmaken met een vochtige, niet-schurende doek of spons met neutrale, niet-schurende poetsmiddelen. Na het schoonmaken de oppervlakte goed naspoeien. Geen agressieve chemische solventen gebruiken zoals trichloorethyleen, solventen en producten die was, bleekmiddel of chloor bevatten. Voor hardnekkige vlekken alcohol of aceton op een zachte doek gebruiken.

Cutting-edge material created for interior design. The outer part of FENIX NTM® is obtained from nano-technologies and features a decorated surface treated with new generation thermoplastic resins which make the surface highly opaque, with low light reflection, resistant to fingerprints, soft to the touch and which allow micro scratches to be removed thermally. Moreover, FENIX NTM® is a material which resists scratches, rubbing, abrasion and blows. It actively impedes bacteria, is hygienic, easy to polish, anti-mould, anti-static, water-repellent and resistant to dry heat.

Maintenance and cleaning

Clean with a soft cloth or humid non-abrasive sponge using neutral and non-abrasive detergents. Rinse the surface carefully after cleaning. Do not use aggressive chemical solvents, such as, trichloroethylene, solvents, wax, bleach or chlorine. Use a soft cloth dampened in alcohol or acetone to remove stubborn stains.



Certificat pour les panneaux en mélaminé et MDF garantissant l'emploi de panneaux à émission de formaldéhyde inférieure au minimum imposé par la norme européenne UNI EN13896.

Certificaat voor panelen in melamine en MDF ter garantie dat er panelen gebruikt worden met een formaldehyde uitstoot die lager ligt dan het wettelijk minimum van de Europese norm UNI EN13896.

Certificate for melamine and MDF panels that guarantees the use of panels with formaldehyde emissions lower than the minimum required by the European standard UNI EN13896.



Certificat de traitement du panneau à la résine hydrofuge.

Certificaat dat de panelen met waterafstotende harsen behandeld werden.

Certificate of treatment of panels with water-repellent resins.



Surface extrêmement mate, faible réflectivité
Zeer mat oppervlak, lage lichtweerkaatsing
Extremely matt surface, low light reflectivity



Résistant aux éraflures
Krasbestendig
Scratch-resistant



Aucune trace de doigts
Anti vingerafdrukken
Anti-fingerprint

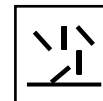

Résistant aux moisissures
Anti schimmel
Mold-resistant



Hygiénique
Hygiënisch
Hygienic



Facile à nettoyer
Gemakkelijk schoon te maken
Easy to clean