



Iks up

mobili | Möbel | muebles

P 51,5 cm



Iks up: com'è realizzato

Iks up: wie es gemacht ist

Iks up: cómo está hecho

① LAVABI

Top con lavabo integrato e in appoggio o semincasso, disponibile in varie forme e materiali.

① WASHBECKEN

Waschtischplatte mit integriertem Waschbecken und Aufsatz- oder Halbeinbauwaschtisch, erhältlich in verschiedenen Formen und Materialien.

① LAVABOS

Encimera con lavabo integrado y lavabo de apoyo o semiempotrado, disponible en varias formas y materiales.

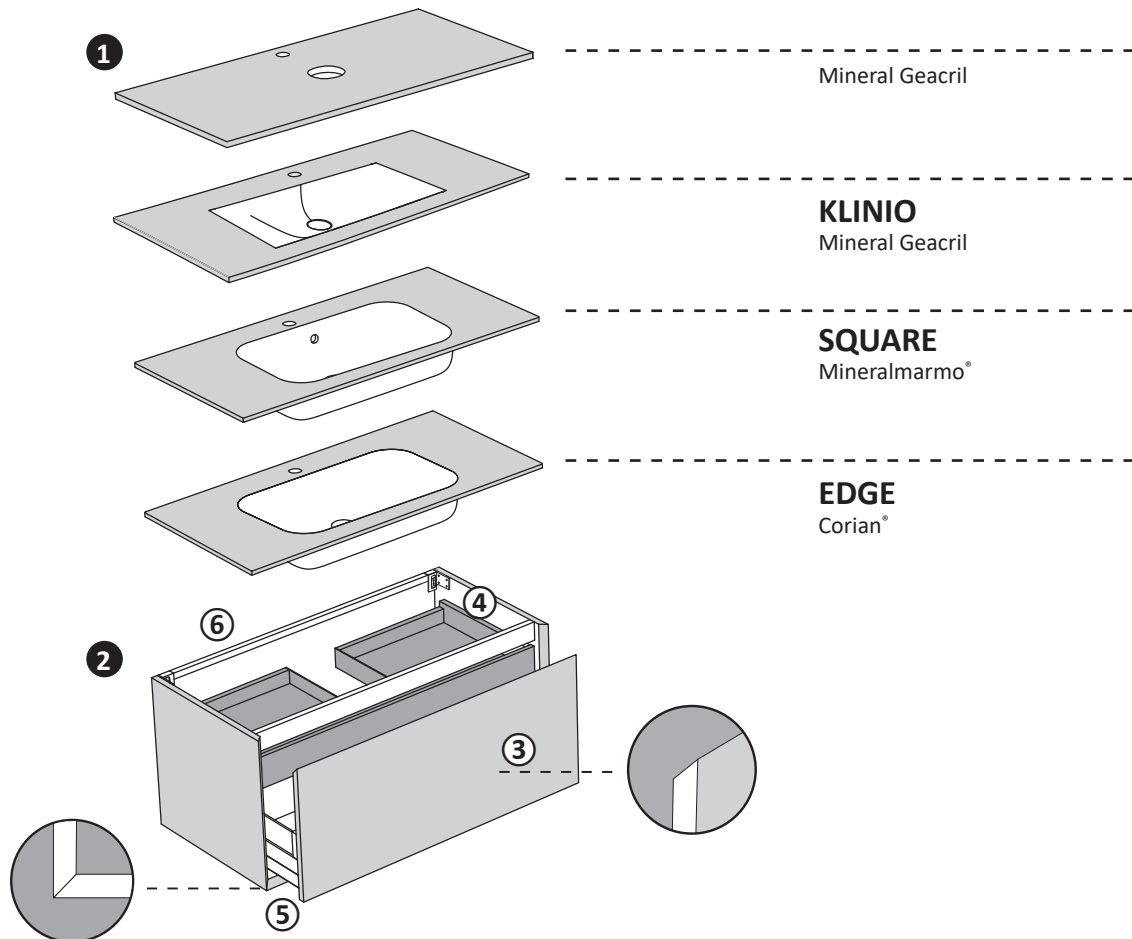

② MOBILE

Realizzato con differenti materiali, naturali o tecnologici, è giuntato a 45° sui due angoli inferiori.

Struttura realizzata con pannelli in MDF Classe E1, W100 impiallacciato legno, oppure con pannelli MDF Classe E1 verniciati.

③ Frontali con apertura a gola sagomata con taglio a 45° realizzati in:

- Finiture laccate con pannello in MDF Classe E1

- Finiture legno con impiallacciatura di legno su pannello in multistrato di betulla o tristrato di rovere

- Finitura gres FG, ceramica laminata su pannello in MDF Classe E1

② MÖBEL

Hergestellt mit verschiedenen Materialien, sowohl natürlich als auch technologisch, ist es bei 45° an den beiden unteren Ecken verbunden.

Struktur aus MDF E1-Klasse, W100 Holz furnierplatten oder aus lackierten E1-Klasse MDF-Platten.

③ Fronten mit geformter Griffmulde mit 45° -Schnitt, hergestellt aus:

- Lackierte Endfertigung mit MDF-Platten der Klasse E1

- Holzendfertigungen Holz furnier auf einer mehrschichtigen Birkenholzplatte

- Endfertigung Gres FG, Lamierte Keramik auf MDF-Platten der Klasse E1

② MUEBLES

Hecho con diferentes materiales, naturales o tecnológicos, se une a 45° en las dos esquinas inferiores.

Estructura hecha con paneles MDF de chapa de madera Clase E1, W100, o con paneles de MDF pintados Clase E1.

③ Frontes con apertura a gola con corte de 45° hechos de:

- Acabados lacados con panel MDF Clase E1

- Acabados de madera con chapa de madera en un panel de madera multicapa de abedul o madera maciza, roble de tres capas

- Acabado gres FG, cerámica laminada en panel de melamina Clase E1

Iks up: com'è realizzato

Iks up: wie es gemacht ist

Iks up: cómo está hecho

④ Struttura interna realizzata con pannelli in melaminico Classe E1, W100 colore grigio antracite

⑤ Cassetti in metallo verniciato e vetro, chiusura soft-system

⑥ Installazione a muro con attacchi a parete regolabili, barre strutturali in alluminio utilizzabili come sistema antigancio.

④ Interne Struktur hergestellt aus Melaminplatten Klasse E1, W100 anthrazitgrau

⑤ Schubladen aus lackiertem Metall und Glas, Soft-Schließsystem

⑥ Wandmontage mit einstellbaren Wandhalterungen, Strukturstangen aus Aluminium, die als Anti-Release-System verwendet werden können.

④ Estructura interna hecha con paneles de melamina Clase E1, W100 gris antracita

⑤ Cajones en metal pintado y vidrio, sistema de cierre soft-system

⑥ Instalación de pared con soportes de pared ajustables, barras estructurales en aluminio que pueden usarse como sistema antidesbloqueo.

Lavorazioni su misura

Kundenspezifische Maßanfertigungen

Realizaciones hechas a medida

Mobili

- Per qualsiasi modifica richiedere fattibilità e preventivo all'ufficio commerciale all'indirizzo email commerciale@stocco.it.
- Colori Ral o a campione supplemento €350 di listino

Möbel

- Für alle Änderung fordern Sie die Durchführbarkeit und ein Angebot beim Verkaufsbüro an unter der E-Mail-Adresse commerciale@stocco.it.
- Ral- und Musterfarben Aufpreis von €350 Listenpreis

Muebles

- Para cualquier modificación solicite factibilidad y presupuesto a la oficina de ventas en la dirección commerciale@stocco.it.
- Colores Ral o de muestra suplemento de €350 de lista

Iks up: materiali e finiture

Iks up: Materialien und Endfertigungen

Iks up: materiales y acabados

STRUTTURA
KORPUS
ESTRUCTURA

CAT. OW - LACCATO BIANCO OPACO
CAT. RN - ROVERE NATURALE
CAT. O - LACCATO COLORATO OPACO

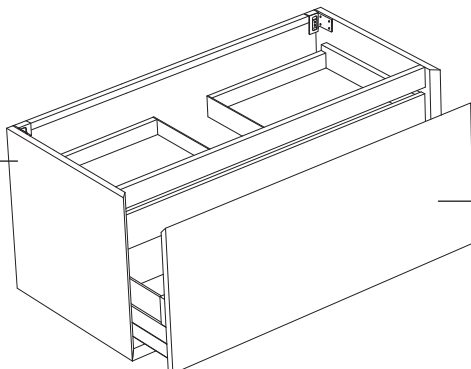

FRONTALE
FRONT
FRONTAL

CAT. RN - ROVERE NATURALE
CAT. LV2 - ROVERE VINTAGE SPACCO NERO
CAT. W5 - ROVERE TERMO-TRATTATO
CAT. NT - NOCE TAN
CAT. OS - OLMO SMOKE
CAT. O - LACCATO OPACO
CAT. B - LACCATO LUCIDO
CAT. FG - GRES

Attenzione: il legno è un prodotto naturale; pertanto l'azienda non può garantire la corrispondenza con i campioni. Qualsiasi variazione del colore, venatura o effetto del legno deve considerarsi non contestabile, rappresentando pregio del materiale e delle lavorazioni artigianali.

Achtung: Holz ist ein Naturprodukt, deshalb kann das Unternehmen nicht die Übereinstimmung mit den Mustern garantieren. Jede Abweichung in der Farbe, Maserung oder im Effekt des Holzes muss als nicht beanstandbar angesehen werden, da es ein Zeichen des Werts des Materials und der handwerklichen Verarbeitung darstellt.

Atención: la madera es un producto natural; por tanto la empresa no puede garantizar la correspondencia con las muestras. Todas variaciones del color, venas o efectos de la madera no pueden ser cuestionados, ya que representan el valor del material y de los trabajos artesanales.

Struttura: materiali e finiture

Korpus: Materialien und Endfertigungen

Estructura: materiales y acabados

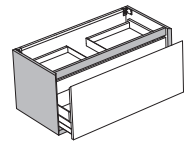

LACCATO / LACKIERT / LACADO

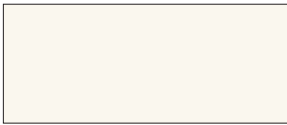

CAT. OW

Laccato Bianco opaco

CAT. O - Laccato opaco / Matt lackiert / Lacado mate

PoppingTrend



O. 283
Salice



O. 281
Savana



O. 36
Bordeaux



O. 285
Oriente



O. 287
Oceano



O. 190
Oltremare

FeelingSoft



O. 182
Salvia



O. 271
Tahiti



O. 273
Santorini



O. 275
Lavanda



O. 277
Lilla



O. 279
Pesca

ForeverChic



O. 20
Bianco

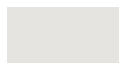

O. 231
Perla



O. 233
Seta

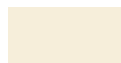

O. 235
Alpaca



O. 172
Lino



O. 180
Avana



O. 237
Argilla



O. 174
Corda



O. 239
Pietra



O. 241
Cervino



O. 243
Dolomiti



O. 245
Arizona



O. 247
Cipria



O. 249
Erica



O. 251
Terra



O. 253
Granata



O. 255
Bosco



O. 257
Oliva



O. 259
Canapa



O. 261
Cotone



O. 263
Efeso



O. 265
Lavaredo



O. 267
Pamir



O. 269
Bromo



O. 198
Grafite



O. 46
Nero

FenixLike



O. 289
Ottawa



O. 291
Londra



O. 263
Efeso



O. 269
Bromo



O. 295
Jaipur



O. 297
Orinoco



O. 293
Fes

LEGNO / HOLZ / MADERA



CAT. RN

Legno Rovere naturale

Frontali: materiali e finiture

Fronten: Materialien und Endfertigungen

Frontales: materiales y acabados

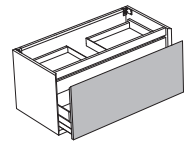

LACCATO / LACKIERT / LACADO

CAT. O - Laccato opaco / Matt lackiert / Lacado mate

CAT. B - Laccato lucido / Glänzend lackiert / Lacado brillante

PoppingTrend



O. 283 - B. 282
Salice



O. 281 - B. 280
Savana



O. 36 - B. 113
Bordeaux



O. 285 - B. 284
Oriente



O. 287 - B. 286
Oceano



O. 190 - B. 189
Oltremare

FeelingSoft



O. 182 - B. 181
Salvia



O. 271 - B. 270
Tahiti



O. 273 - B. 272
Santorini



O. 275 - B. 274
Lavanda



O. 277 - B. 276
Lilla



O. 279 - B. 278
Pesca

ForeverChic



O. 20 - B. 21
Bianco

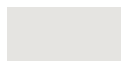

O. 231 - B. 230
Perla



O. 233 - B. 232
Seta

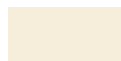

O. 235 - B. 234
Alpaca



O. 172 - B. 171
Lino



O. 180 - B. 179
Avana



O. 237 - B. 236
Argilla



O. 174 - B. 173
Corda



O. 239 - B. 238
Pietra



O. 241 - B. 240
Cervino



O. 243 - B. 242
Dolomiti



O. 245 - B. 244
Arizona



O. 247 - B. 246
Cipria



O. 249 - B. 248
Erica



O. 251 - B. 250
Terra



O. 253 - B. 252
Granata



O. 255 - B. 254
Bosco



O. 257 - B. 256
Oliva



O. 259 - B. 258
Canapa



O. 261 - B. 260
Cotone



O. 263 - B. 262
Efeso



O. 265 - B. 264
Lavaredo



O. 267 - B. 266
Pamir



O. 269 - B. 268
Bromo



O. 198 - B. 104
Grafite



O. 46 - B. 100
Nero

FenixLike



O. 289 - B. 288
Ottawa



O. 291 - B. 290
Londra



O. 263 - B. 262
Efeso



O. 269 - B. 268
Bromo



O. 295 - B. 294
Jaipur



O. 297 - B. 296
Orinoco



O. 293 - B. 292
Fes

LEGNO / HOLZ / MADERA

Venatura orizzontale / Waagerechte Maserung / Grano horizontal



CAT. RN
Legno Rovere naturale



CAT. LV2
Legno Rovere Vintage
con spacco nero



CAT. W5
Legno Rovere
termo-trattato

Venatura verticale / Senkrechte Maserung / Grano vertical



CAT. OS
Legno Olmo Smoke



CAT. NT
Legno Noce Tan

Frontali: materiali e finiture

Fronten: Materialien und Endfertigungen

Frontales: materiales y acabados

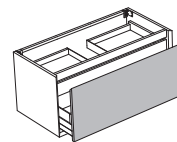

GRES

CAT. FG

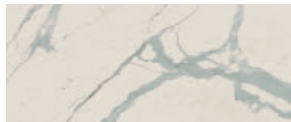

Gres opaco / Gres matt / Gres mate

FG01

Bianco Statuario Venato
opaco



FG03

Oro Venato opaco



FG05

Nero Marquina opaco

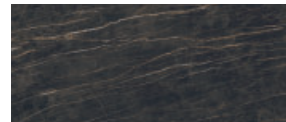

FG07

Noir Desir opaco

Gres lucido / Gres glänzend / Gres brillante

FG02

Bianco Statuario Venato
lucidato

FG04

Oro Venato lucidato

FG06

Nero Marquina lucidato











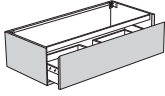
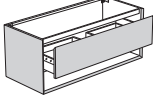
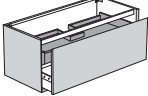
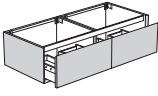
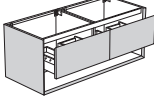
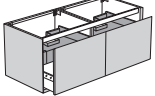















































FG08

Noir Desir lucidato

Iks up: panoramica prodotti

Iks up: Produktübersicht

Iks up: visión general del producto

						
	H.34	H.50	H.50	H.34	H.50	H.50
L.70						
L.90						
L.100						
L.120	   	   	   	  	  	  
L.140				  	  	  
L.160				  	  	  
L.180				  	  	  



Iks full Frame

mobili | Möbel | muebles

P 53 cm

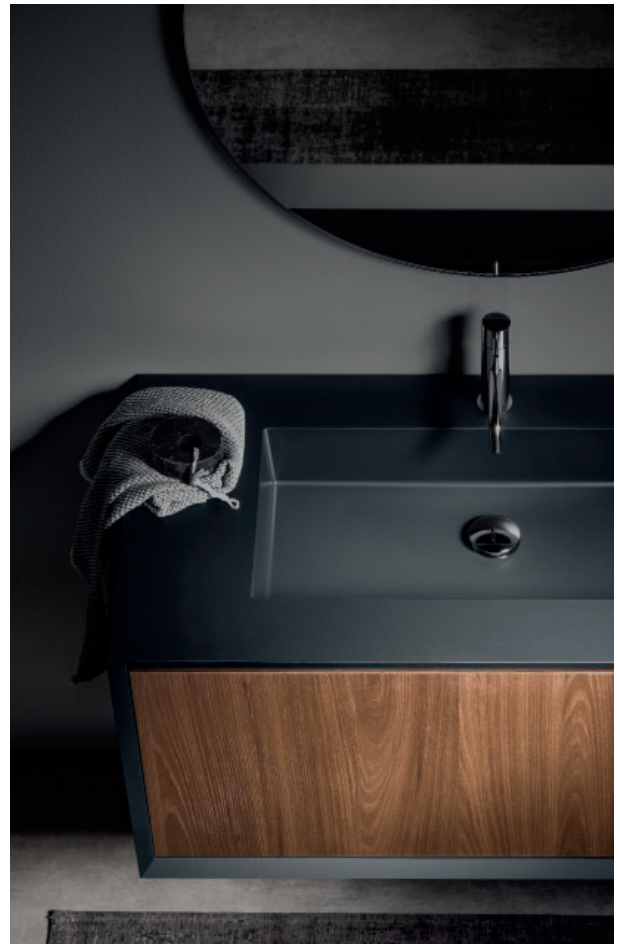

Iks full Frame: com'è realizzato

Iks full Frame: wie es gemacht ist

Iks full Frame: cómo está hecho

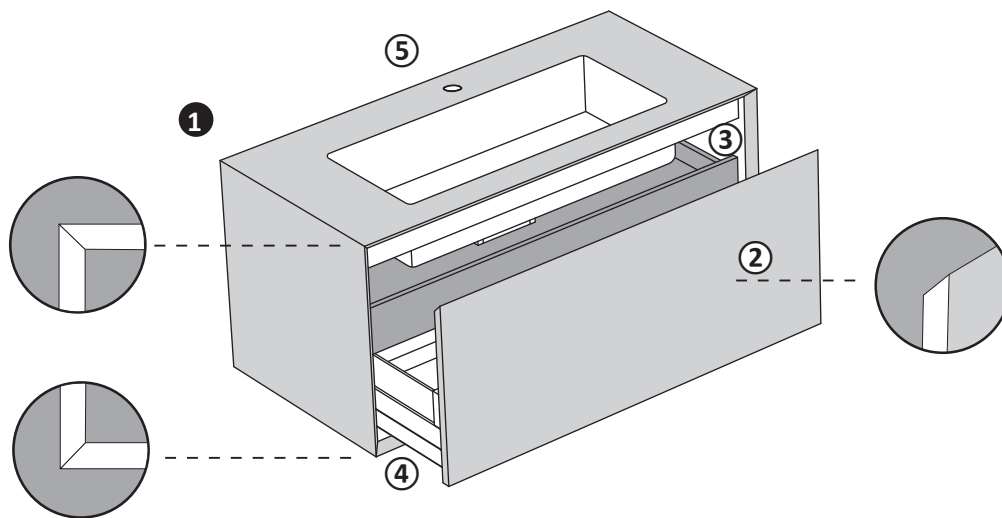

① MOBILE

Realizzato con differenti materiali, naturali o tecnologici è giuntato a 45° sui quattro angoli.

Struttura realizzata con pannelli in melaminico Classe E1, W100 Fenix®, con lavabo integrato

② Frontali con apertura a gola sagomata con taglio a 45°, realizzati in:

- Finiture laccate con pannello in MDF classe E1

- Finiture legno impiallacciatura di legno su pannello in multistrato di betulla o tristrato di rovere
- Finitura gres FG, ceramica laminata su pannello in MDF Classe E1

③ Struttura interna realizzata con pannelli in melaminico Classe E1, W100 colore grigio antracite

④ Cassetti in metallo verniciato e vetro, chiusura soft-system

⑤ Installazione a muro con attacchi a parete regolabili, barre strutturali in alluminio dotate di sistema antiscivolo.

① MÖBEL

Hergestellt mit verschiedenen Materialien, sowohl natürlich als auch technologisch, ist es bei 45° an den vier Ecken verbunden.

Struktur aus Klasse E1, W100 Melaminplatten Fenix®, mit integriertem Waschbecken.

② Fronten mit geformter Griffmulde mit 45°-Schnitt, hergestellt aus:

- Lackierte Endfertigung mit MDF-Platten der Klasse E1

- Holzendfertigungen aus Holzfurnier auf einer mehrschichtigen Birkenholzplatte

- Endfertigung Gres FG, Laminierte Keramik auf Melaminplatte Klasse E1

③ Interne Struktur hergestellt aus Melaminplatten Klasse E1, W100 anthrazitgrau

④ Schubladen aus lackiertem Metall und Glas, Soft-Schließsystem

⑤ Wandmontage mit einstellbaren Wandhalterungen, Strukturstangen aus Aluminium, ausgestattet mit Anti-Release-System.

① MUEBLE

Hecho con diferentes materiales, naturales o tecnológicos, se une a 45° en las cuatro esquinas.

Estructura hecha con paneles de melamina Clase E1, W100 Fenix®, con lavabo integrado.

② Frentes con apertura a gola con corte de 45°, hechos de:

- Acabados lacados con panel MDF Clase E1

- Acabados de madera en chapa de madera en un panel de madera multicapa de abedul o madera maciza, roble de tres capas

- acabado Gres FG, cerámica laminada en panel de melamina Clase E1

③ Estructura interna hecha con paneles de melamina Clase E1, W100 gris antracita

④ Cajones en metal pintado y vidrio, sistema de cierre soft-system

⑤ Instalación de pared con soportes de pared ajustables, barras estructurales en aluminio equipadas con sistema antidesbloqueo.

Lavorazioni su misura

Kundenspezifische Maßanfertigungen

Realizaciones hechas a medida

Mobili e lavabo applicato

- Per qualsiasi modifica richiedere fattibilità e preventivo all'ufficio commerciale all'indirizzo email commerciale@stocco.it.
- Colori Ral o a campione: solo per i frontali, supplemento €350 di listino
- Senza foro miscelatore su richiesta: nell'ordine indicare il codice SF.

Möbel und Waschbecken

- Für alle Änderung fordern Sie die Durchführbarkeit und ein Angebot beim Verkaufsbüro an unter der E-Mail-Adresse commerciale@stocco.it.
- Ral- und Musterfarben: nur für die Fronten, Aufpreis von €350 Listenpreis
- Auf Anfrage auch ohne Bohrungen für die Armaturen, geben Sie in der Bestellung den Code SF an.

Muebles y lavabos

- Para cualquier modificación solicite factibilidad y presupuesto a la oficina de ventas en la dirección commerciale@stocco.it.
- Colores Ral o de muestra: solo para los frentes, suplemento de €350 de lista
- Sin orificio mezclador a petición, especificar en el pedido el código SF.

Iks full Frame: materiali e finiture

Iks full Frame: Materialien und Endfertigungen

Iks full Frame: materiales y acabados

STRUTTURA

KORPUS

ESTRUCTURA

CAT. AF - FENIX

CAT. BF - FENIX COLORATO

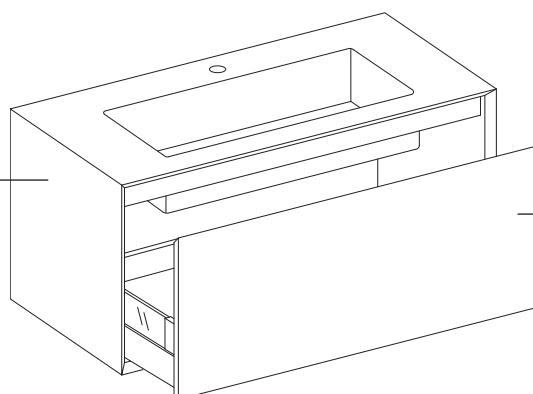

FRONTALE

FRONT

FRONTAL

CAT. O - LACCATO OPACO

CAT. B - LACCATO LUCIDO

CAT. RN - ROVERE NATURALE

CAT. LV2 - ROVERE VINTAGE NERO

CAT. NT - NOCE TAN

CAT. OS - OLMO SMOKE

CAT. W5 - ROVERE TERMO-TRATTATO

CAT. FG - GRES

Attenzione: il legno è un prodotto naturale; pertanto l'azienda non può garantire la corrispondenza con i campioni. Qualsiasi variazione del colore, venatura o effetto del legno deve considerarsi non contestabile, rappresentando pregio del materiale e delle lavorazioni artigianali.

Achtung: Holz ist ein Naturprodukt, deshalb kann das Unternehmen nicht die Übereinstimmung mit den Mustern garantieren. Jede Abweichung in der Farbe, Maserung oder im Effekt des Holzes muss als nicht beanstandbar angesehen werden, da es ein Zeichen des Werts des Materials und der handwerklichen Verarbeitung darstellt.

Atención: la madera es un producto natural; por tanto la empresa no puede garantizar la correspondencia con las muestras. Todas variaciones del color, venas o efectos de la madera no pueden ser cuestionados, ya que representan el valor del material y de los trabajos artesanales.

Struttura: materiali e finiture

Korpus: Materialien und Endfertigungen

Estructura: materiales y acabados

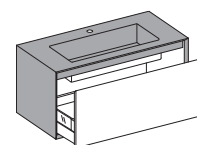

FENIX®

CAT. AF - FENIX

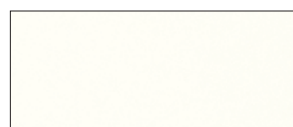

FX32

Bianco Kos



FX720

Nero Ingo

CAT. BF - FENIX COLORATO



FX717

Castoro Ottawa



FX718

Grigio Londra



FX725

Grigio Efeso



FX724

Grigio Bromo



FX751

Rosso Jaipur



* FX749

Cacao Orinoco



FX754

Blu Fes

* FX749

Cacao Orinoco

Non disponibile

Nicht verfügbar

No disponible

Frontali: materiali e finiture

Fronten: Materialien und Endfertigungen

Frontales: materiales y acabados

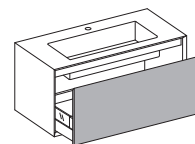

LACCATO / LACKIERT / LACADO

CAT. O - Laccato opaco / Matt lackiert / Lacado mate

CAT. B - Laccato lucido / Glänzend lackiert / Lacado brillante

PoppingTrend



O. 283 - B. 282
Salice



O. 281 - B. 280
Savana



O. 36 - B. 113
Bordeaux



O. 285 - B. 284
Oriente



O. 287 - B. 286
Oceano



O. 190 - B. 189
Oltremare

FeelingSoft



O. 182 - B. 181
Salvia



O. 271 - B. 270
Tahiti



O. 273 - B. 272
Santorini



O. 275 - B. 274
Lavanda



O. 277 - B. 276
Lilla



O. 279 - B. 278
Pesca

ForeverChic



O. 20 - B. 21
Bianco

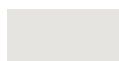

O. 231 - B. 230
Perla



O. 233 - B. 232
Seta

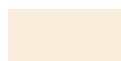

O. 235 - B. 234
Alpaca



O. 172 - B. 171
Lino



O. 180 - B. 179
Avana



O. 237 - B. 236
Argilla



O. 174 - B. 173
Corda



O. 239 - B. 238
Pietra



O. 241 - B. 240
Cervino



O. 243 - B. 242
Dolomiti



O. 245 - B. 244
Arizona



O. 247 - B. 246
Cipria



O. 249 - B. 248
Erica



O. 251 - B. 250
Terra



O. 253 - B. 252
Granata



O. 255 - B. 254
Bosco



O. 257 - B. 256
Oliva



O. 259 - B. 258
Canapa



O. 261 - B. 260
Cotone



O. 263 - B. 262
Efeso



O. 265 - B. 264
Lavaredo



O. 267 - B. 266
Pamir



O. 269 - B. 268
Bromo



O. 198 - B. 104
Grafite



O. 46 - B. 100
Nero

FenixLike



O. 289 - B. 288
Ottawa



O. 291 - B. 290
Londra



O. 263 - B. 262
Efeso



O. 269 - B. 268
Bromo



O. 295 - B. 294
Jaipur



O. 297 - B. 296
Orinoco



O. 293 - B. 292
Fes

LEGNO / HOLZ / MADERA

Venatura orizzontale / Waagerechte Maserung / Grano horizontal



CAT. RN
Legno Rovere naturale



CAT. LV2
Legno Rovere Vintage
con spacco nero



CAT. W5
Legno Rovere
termo-trattato

Venatura verticale / Senkrechte Maserung / Grano vertical



CAT. OS
Legno Olmo Smoke



CAT. NT
Legno Noce Tan

Frontali: materiali e finiture

Fronten: Materialien und Endfertigungen

Frontales: materiales y acabados

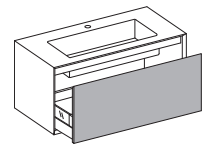

GRES

CAT. FG



Gres opaco / Gres matt / Gres mate

FG01
Bianco Statuario Venato
opaco



FG03
Oro Venato opaco



FG05
Nero Marquina opaco

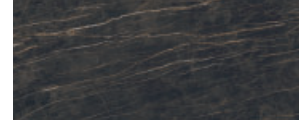

FG07
Noir Desir opaco

Gres lucido / Gres glänzend / Gres brillante

FG02
Bianco Statuario Venato
lucidato

FG04
Oro Venato lucidato

FG06
Nero Marquina lucidato

FG08
Noir Desir lucidato

Iks full Frame: top

Iks full Frame: Waschtischplatten

Iks full Frame: encimeras



Di serie: vasca Fenix in materiale composito nanotecnologico, foro miscelatore, piletta e copripiletta a scarico libero cromate

Non compreso: troppopieno

Serienmäßig: Fenix Becken aus nanotechnologischem Verbundwerkstoff, Hahnloch, verchromte Ablaufgarnitur und Ablaufdeckel mit freiem Ablauf

Nicht eingeschlossen: Überlauf

Estándar: Lavabo Fenix en material compuesto nanotecnológico, orificio mezclador, desagüe y cubrepiletta cromada con descarga libre

No incluido: rebosadero

Disponibile nelle seguenti versioni:

Erhältlich in den folgenden Ausführungen:

Disponibile en las siguientes versiones:

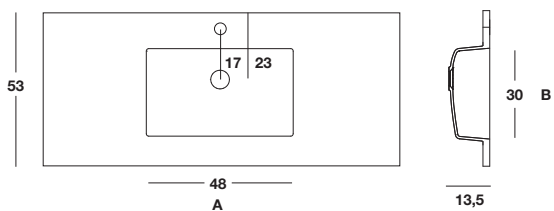

CX L 70 - 90

SX L 120 - 140 - 160

DX L 120 - 140 - 160

L 140 - 160

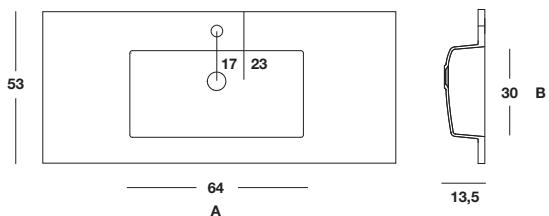

CX L 100 - L 120

SX L 180

DX L 180

L 180

Compatibilità sifone salvaspazio per lavabi integrati

Kompatibilität des platzsparenden Siphons mit integrierten Waschbecken

Compatibilidad de el sifón ahorra espacio con lavabos integrados

Iks full Frame

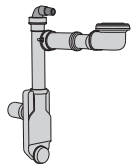

FRAME













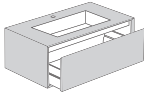
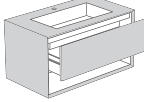
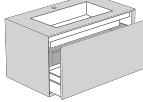
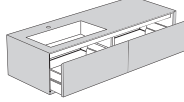
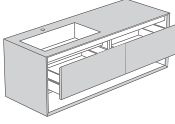
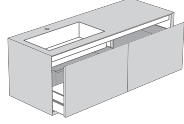



































H.36,5		✓
H.52		✓
H.52		✓

→ 686 **Informazioni per la progettazione**
Design informationen
Informaciones de diseño

Iks full Frame: panoramica prodotti

Iks full Frame: Produktübersicht

Iks full Frame: visión general del producto

						
	H.36,5	H.52	H.52	H.36,5	H.52	H.52
L.70,5						
L.90,5						
L.100,5						
L.120,5	  	  	  			
L.140				  	  	  
L.160				  	  	  
L.180				  	  	  



Iks mobili

mobili | Möbel | muebles

P 53 cm



Iks mobile: com'è realizzato

Iks Möbel: wie es gemacht ist

Iks mueble: cómo está hecho

Iks mobile

Iks Möbel

Iks mueble

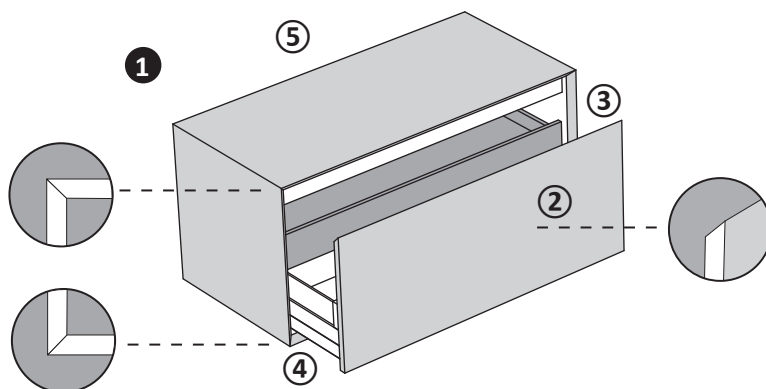

Iks mobile per lavabo in appoggio

Iks Möbel für Aufsatzwaschbecken

Iks mueble para lavabo en apoyo

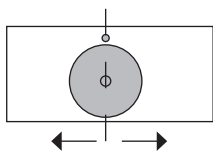
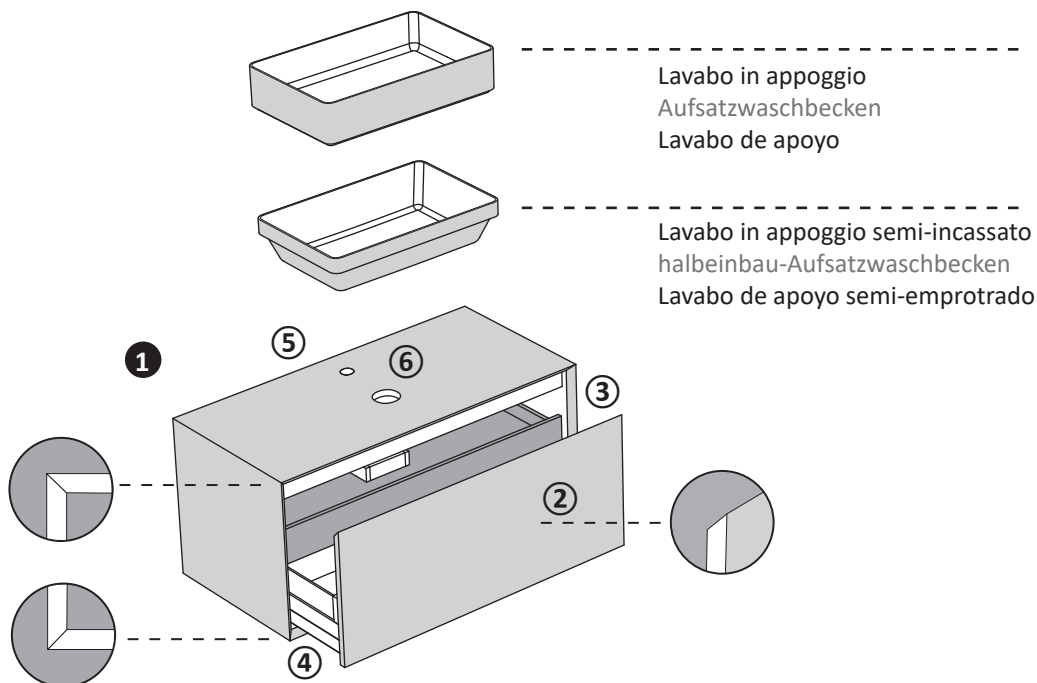

Attenzione: allegare all'ordine un disegno tecnico con indicati il lavabo scelto, la posizione del lavabo e del foro mixer.

Achtung: fügen Sie der Bestellung eine technische Zeichnung hinzu, mit Angabe von dem gewählten Becken, der Position des Waschbeckens und der Bohrung für die Armaturen.

Atención: añadir al pedido un dibujo técnico indicando el lavabo elegido, la posición del lavabo y del orificio mezclador.

Iks mobile: com'è realizzato

Iks Möbel: wie es gemacht ist

Iks mueble: cómo está hecho

① MOBILE

Realizzato con differenti materiali, naturali o tecnologici è giuntato a 45° sui quattro angoli.

Struttura realizzata con pannelli in melamminico Classe E1, W100 Fenix®.

② Frontali con apertura a gola sagomata con taglio a 45°, realizzati in:

- Finiture laccate con pannello in MDF classe E1

- Finiture legno impiallacciatura di legno su pannello in multistrato di betulla o tristrato di rovere

- Finitura gres FG, ceramica laminata su pannello in MDF Classe E1

③ Struttura interna realizzata con pannelli in melamminico Classe E1, W100 colore grigio antracite

④ Cassetti in metallo verniciato e vetro, chiusura soft-system

⑤ Installazione a muro con attacchi a parete regolabili, barre strutturali in alluminio dotate di sistema antigancio.

① MÖBEL

Hergestellt mit verschiedenen Materialien, sowohl natürlich als auch technologisch, ist es bei 45° an den vier Ecken verbunden.

Struktur aus Klasse E1, W100 Melaminplatten Fenix®.

② Fronten mit geformter Griffmulde mit 45° -Schnitt, hergestellt aus:

- Lackierte Endfertigung mit MDF-Platten der Klasse E1

- Holzendfertigungen aus Holzfurnier auf einer mehrschichtigen Birkenholzplatte

- Endfertigung Gres FG, Lamierte Keramik auf Melaminplatte Klasse E1

③ Interne Struktur hergestellt aus Melaminplatten Klasse E1, W100 anthrazitgrau

④ Schubladen aus lackiertem Metall und Glas, Soft-Schließsystem

⑤ Wandmontage mit einstellbaren Wandhalterungen, Strukturstangen aus Aluminium, ausgestattet mit Anti-Release-System.

① MUEBLE

Hecho con diferentes materiales, naturales o tecnológicos, se une a 45° en las cuatro esquinas.

Estructura hecha con paneles de melamina Clase E1, W100 Fenix®.

② Frentes con abertura a gola con corte de 45°, hechos de:

- Acabados lacados con panel MDF Clase E1

- Acabados de madera en chapa de madera en un panel de madera multicapa de abedul o madera maciza, roble de tres capas

- acabado Gres FG, cerámica laminada en panel de melamina Clase E1

③ Estructura interna hecha con paneles de melamina Clase E1, W100 gris antracita

④ Cajones en metal pintado y vidrio, sistema de cierre soft-system

⑤ Instalación de pared con soportes de pared ajustables, barras estructurales en aluminio equipadas con sistema antidesbloqueo.

Lavorazioni su misura

Kundenspezifische Maßanfertigungen

Realizaciones hechas a medida

Mobili

- Per qualsiasi modifica richiedere fattibilità e preventivo all'ufficio commerciale all'indirizzo email commerciale@stocco.it.
- Colori Ral o a campione: solo per i frontali, supplemento €350 di listino

Möbel

- Für alle Änderung fordern Sie die Durchführbarkeit und ein Angebot beim Verkaufsbüro an unter der E-Mail-Adresse commerciale@stocco.it.
- Ral- und Musterfarben: nur für die Fronten, Aufpreis von €350 Listenpreis

Muebles

- Para cualquier modificación solicite factibilidad y presupuesto a la oficina de ventas en la dirección commerciale@stocco.it.
- Colores Ral o de muestra: solo para los frentes, suplemento de €350 de lista

Iks mobile: materiali e finiture

Iks Möbel: Materialien und Endfertigungen

Iks mueble: materiales y acabados

STRUTTURA

KORPUS

ESTRUCTURA

CAT. AF - FENIX

CAT. BF - FENIX COLORATO

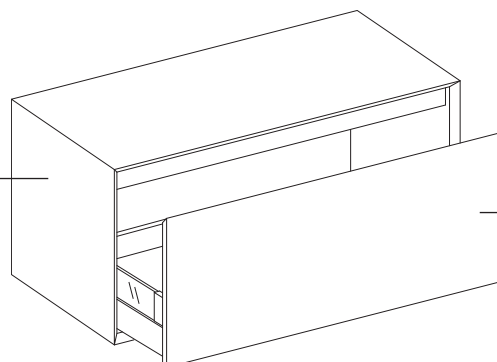

FRONTALE

FRONT

FRONTAL

CAT. RN - ROVERE NATURALE

CAT. LV2 - ROVERE VINTAGE SPACCO NERO

CAT. W5 - ROVERE TERMO-TRATTATO

CAT. NT - NOCE TAN

CAT. OS - OLMO SMOKE

CAT. O - LACCATO OPACO

CAT. B - LACCATO LUCIDO

CAT. FG - GRES

Attenzione: il legno è un prodotto naturale; pertanto l'azienda non può garantire la corrispondenza con i campioni. Qualsiasi variazione del colore, venatura o effetto del legno deve considerarsi non contestabile, rappresentando pregio del materiale e delle lavorazioni artigianali.

Achtung: Holz ist ein Naturprodukt, deshalb kann das Unternehmen nicht die Übereinstimmung mit den Mustern garantieren. Jede Abweichung in der Farbe, Maserung oder im Effekt des Holzes muss als nicht beanstandbar angesehen werden, da es ein Zeichen des Werts des Materials und der handwerklichen Verarbeitung darstellt.

Atención: la madera es un producto natural; por tanto la empresa no puede garantizar la correspondencia con las muestras. Todas variaciones del color, venas o efectos de la madera no pueden ser cuestionados, ya que representan el valor del material y de los trabajos artesanales.

Struttura: materiali e finiture

Korpus: Materialien und Endfertigungen

Estructura: materiales y acabados

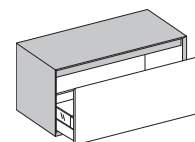

FENIX®

CAT. AF - FENIX

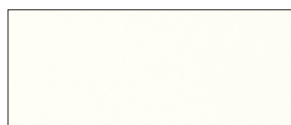

FX32

Bianco Kos

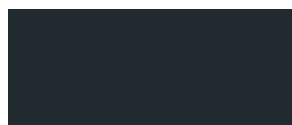

FX720

Nero Ingo

CAT. BF - FENIX COLORATO



FX717

Castoro Ottawa



FX718

Grigio Londra



FX725

Grigio Efeso



FX724

Grigio Bromo



FX751

Rosso Jaipur



FX749

Cacao Orinoco



FX754

Blu Fes

Frontale: materiali e finiture

Fronten: Materialien und Endfertigungen

Frontales: materiales y acabados

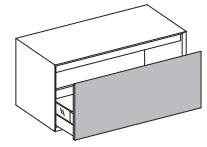

LACCATO / LACKIERT / LACADO

CAT. O - Laccato opaco / Matt lackiert / Lacado mate

CAT. B - Laccato lucido / Glänzend lackiert / Lacado brillante

PoppingTrend



O. 283 - B. 282
Salice



O. 281 - B. 280
Savana



O. 36 - B. 113
Bordeaux



O. 285 - B. 284
Oriente



O. 287 - B. 286
Oceano



O. 190 - B. 189
Oltremare

FeelingSoft



O. 182 - B. 181
Salvia



O. 271 - B. 270
Tahiti



O. 273 - B. 272
Santorini



O. 275 - B. 274
Lavanda



O. 277 - B. 276
Lilla



O. 279 - B. 278
Pesca

ForeverChic



O. 20 - B. 21
Bianco

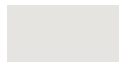

O. 231 - B. 230
Perla



O. 233 - B. 232
Seta

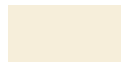

O. 235 - B. 234
Alpaca



O. 172 - B. 171
Lino



O. 180 - B. 179
Avana



O. 237 - B. 236
Argilla



O. 174 - B. 173
Corda



O. 239 - B. 238
Pietra



O. 241 - B. 240
Cervino



O. 243 - B. 242
Dolomiti



O. 245 - B. 244
Arizona



O. 247 - B. 246
Cipria



O. 249 - B. 248
Erica



O. 251 - B. 250
Terra



O. 253 - B. 252
Granata



O. 255 - B. 254
Bosco



O. 257 - B. 256
Oliva



O. 259 - B. 258
Canapa



O. 261 - B. 260
Cotone



O. 263 - B. 262
Efeso



O. 265 - B. 264
Lavaredo



O. 267 - B. 266
Pamir



O. 269 - B. 268
Bromo



O. 198 - B. 104
Grafite



O. 46 - B. 100
Nero

FenixLike



O. 289 - B. 288
Ottawa



O. 291 - B. 290
Londra



O. 263 - B. 262
Efeso



O. 269 - B. 268
Bromo



O. 295 - B. 294
Jaipur



O. 297 - B. 296
Orinoco



O. 293 - B. 292
Fes

LEGNO / HOLZ / MADERA

Venatura orizzontale / Waagerechte Maserung / Grano horizontal



CAT. RN
Legno Rovere naturale



CAT. LV2
Legno Rovere Vintage
con spacco nero



CAT. W5
Legno Rovere
termo-trattato

Venatura verticale / Senkrechte Maserung / Grano vertical



CAT. OS
Legno Olmo Smoke



CAT. NT
Legno Noce Tan

Frontale: materiali e finiture

Fronten: Materialien und Endfertigungen

Frontales: materiales y acabados

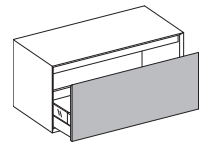

GRES

CAT. FG



Gres opaco / Gres matt / Gres mate

FG01

Bianco Statuario Venato
opaco



FG03

Oro Venato opaco



FG05

Nero Marquina opaco

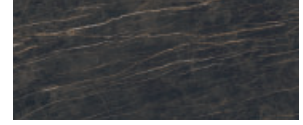

FG07

Noir Desir opaco

Gres lucido / Gres glänzend / Gres brillante

FG02

Bianco Statuario Venato
lucidato

FG04

Oro Venato lucidato

FG06

Nero Marquina lucidato

FG08

Noir Desir lucidato

Iks mobile: panoramica prodotti

Iks Möbel: Produktübersicht

Iks mueble: visión general del producto

Iks mobile

Iks Möbel

Iks mueble

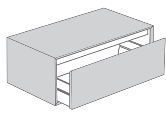
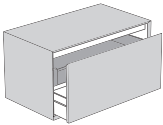
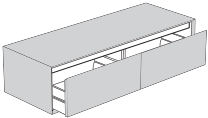
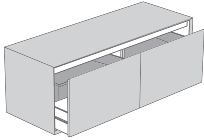









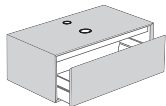
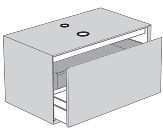
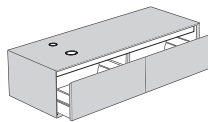
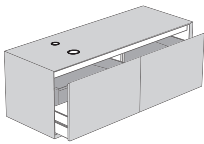



				
	H.36,5	H.52	H.36,5	H.52
L.70,5	•	•		
L.90,5	•	•		
L.100,5	•	•		
L.120,5	•	•		
L.140			•	•
L.160			•	•
L.180			•	•

• Disponibile | Verfügbar | Disponible

Iks mobile per lavabo in appoggio

Iks Möbel für Aufsatzwaschbecken

Iks mueble para lavabo en apoyo

				
	H.36,5	H.52	H.36,5	H.52
L.70,5				
L.90,5				
L.100,5				
L.120,5				
L.140				
L.160				
L.180				

Colori laccati

Lackierte Farben

Colores lacados

Frutto di una costante ricerca del colore, ispirata e influenzata dalle tendenze più attuali in fatto di arredo, moda e design, la palette presenta un'ampia scelta di colori e finiture. I frontali sono realizzati in MDF poliesterato e levigato, indice di alta qualità e cura nella scelta dei materiali più idonei per una laccatura eccellente. La laccatura in finitura opaca, grazie all'impiego di vernici con microsferiche ceramiche, ne aumenta la resistenza. Per la laccatura lucida sono impiegate vernici poliuretaniche e le parti curve sono addirittura spazzolate a mano da abili artigiani. I colori laccati metallizzati sono realizzati aggiungendo vere polveri di metallo alle vernici. Per tutti i componenti laccati, infine, applichiamo rigorosi controlli di qualità, controllando ogni singolo pezzo per garantire massima qualità e precisione.

Manutenzione e pulizia

Pulire con panno morbido o spugna non abrasiva umida utilizzando detergenti neutri non abrasivi. Al termine dell'operazione di pulizia risciacquare bene la superficie. Non utilizzare solventi chimici aggressivi quali acetone, trielina e solventi. Solo sul laccato lucido, in caso di macchie persistenti, utilizzare un panno morbido con prodotti per la pulizia dei vetri o sapone neutro. Non usare ammoniaca. Si consiglia di provare qualsiasi prodotto nella parte interna della superficie, in un angolo, prima di utilizzarlo nella parte esterna. Asciugare accuratamente le superfici dopo l'uso.

Das Ergebnis einer ständigen Forschung im Bereich der Farben, inspiriert durch die neuesten Trends in Bezug auf Möbel, Mode und Design, bietet die Farbpalette eine große Auswahl an Farben und Oberflächen. Die Fronten bestehen aus Polyester-MDF und geschliffenen MDF, was ein Zeichen von hoher Qualität und Sorgfalt bei der Auswahl der am besten geeigneten Materialien für eine hervorragende Lackierung ist. Der matte Lack wird dank der Verwendung von Farben mit Keramik-Mikrokugeln erhalten, was dessen Widerstandskraft erhöht. Für den Hochglanzlack werden Polyurethan-Beschichtungen verwendet und die gekrümmten Teile werden sogar von Hand gebürstet, von erfahrenen Handwerkern. Die metallischen Lackfarben werden durch Zugabe von echten Metallpulverbeschichtungen erhalten. Für alle lackierten Komponente wenden wir schließlich eine strenge Qualitätskontrolle an, mit der Überprüfung jedes einzelnen Stückes, um maximale Qualität und Präzision zu gewährleisten.

Wartung und Reinigung

Mit einem weichen feuchten Tuch oder einem nicht-scheuernden Schwamm mit einem milden, nicht scheuernden Reinigungsmitteln reinigen. Nach der Reinigung spülen Sie die Oberfläche gut ab. Verwenden Sie keine scharfen chemischen Lösungsmitteln, wie Aceton, Trichlorethylen oder Lösungsmittel. Nur bei den glänzend lackierten Produkten verwenden Sie bei hartnäckigen Flecken ein weiches Tuch mit Glasreinigern oder milder Seife. Kein Ammoniak verwenden. Wir raten dazu alle Produkte erst auf der Innenfläche, in einer nicht sichtbaren Ecke zu testen bevor Sie es an der Außenseite verwenden. Trocknen Sie die Flächen nach dem Gebrauch gründlich ab.

Fruto de una búsqueda constante del color, inspirada e influenciada por las tendencias más actuales en muebles, moda y diseño, la paleta presenta una amplia selección de colores y acabados. Los frontales están realizados en MDF recubierto de poliéster y pulido, señal de alta calidad y cuidado en la elección de los materiales idóneos para un lacado excelente. El lacado con acabado mate, gracias a la utilización de barnices con microesferas de cerámica, aumenta su resistencia. Para el lacado brillante se emplean barnices de poliuretano y las partes curvas son incluso cepilladas a mano por hábiles artesanos. Los colores lacados metalizados se realizan añadiendo auténtico polvo de metal a los barnices. Finalmente, en todos los componentes lacados aplicamos rigurosos controles de calidad, controlando cada pieza individual para garantizar la máxima calidad y precisión.

Mantenimiento y limpieza

Limpiar con un paño suave o esponja no abrasiva húmeda, utilizando detergentes neutros no abrasivos. Al finalizar la operación de limpieza aclarar bien la superficie. No utilizar disolventes químicos agresivos como acetonas, tricloroetileno y disolventes. Solo sobre el lacado brillante, en caso de manchas resistentes utilizar un paño suave con productos para la limpieza del vidrio o jabón neutro. No utilizar amoníaco. Se aconseja probar el producto sobre la parte interna de la superficie, en un ángulo, antes de utilizarlo sobre la parte externa. Secar bien las superficies tras el uso.



Igienico
hygienisch
Higiénico



Facile da pulire
Leicht zu reinigen
De fácil limpieza

Legno

Holz

Madera

La proposta dei legni è pensata per chi predilige un materiale dal fascino naturale. Presenta un'ampia scelta di finiture legno impiallacciato per top mensole, mobili e frontali, trattate per l'utilizzo nell'ambiente bagno.

Il Rovere naturale e Walnut naturale (noce americano) sono verniciati in acrilico trasparente.

Il Rovere Safari è tinto e verniciato in acrilico trasparente.

Il Rovere Vintage e Rovere termo-trattato sono ricavati da interni briccola o piante molto nodose con la caratteristica diversità di colore dovuta all'esposizione agli agenti atmosferici. Presentano spaccature midollari e nodi aperti, anche a forma di stella.

L'impiallaccio del Rovere Vintage è completato con supporto nero per evidenziare la finitura a spacco.

Il Rovere termo-trattato è tri-strato trattato ad alte temperature, verniciato in acrilico trasparente con spaccature stuccate parzialmente in nero oppure sbiancato.

L'impiallaccio del Rovere Termocotto è trattato ad alte temperature e verniciato in acrilico trasparente.

Il Noce Tan ha una colorazione naturale con marcati effetti di chiaroscuro, è verniciato in acrilico trasparente, con leggera spazzolatura.

L'Olmo Smoke è scurito naturalmente con trattamento di affumicatura in autoclave, verniciato in acrilico trasparente e spazzolato.

I legni selezionati

Il legno è una materia che ha una sua unicità e originalità. Per tale caratteristica, si possono riscontrare delle differenze di venatura e tonalità di colore che rientrano nelle tolleranze previste dagli standard.

Das Angebot von Holz-Endfertigungen ist für diejenigen gedacht, die ein Material mit natürlichem Charme bevorzugen. Es bietet eine große Auswahl an furnierten Holzoberflächen für Konsolen, Möbel und Fronten, die für den Einsatz im Badezimmer behandelt werden.

Die Natur-Eiche und Walnuss (Amerikanische Walnuss) sind mit durchsichtigem Acryllack lackiert.

Die Vintage Eiche und die thermobehandelte Eiche werden aus Dalbenholz oder sehr knorrigen Pflanzen gewonnen, welche die charakteristischen Farbunterschiede aufweisen die durch die Aussetzung des Holzes an die Naturelemente entstehen. Es weist offene Spalte und Astlöcher in Sternform auf. Das Furnier wird vollendet mit hellem oder schwarzem Untergrund, um die gespalten Endfertigung hervorzuheben.

Das bei hohen Temperaturen thermobehandelte Holz ist ein Dreilagiges Holz, mit durchsichtigem Acryllack lackiert mit teilweise schwarz gefüllten oder gebleichten Spalten.

Das Furnier der Termocotto Eiche wird bei hohen Temperaturen behandelt und in transparentem Acryl lackiert.

Das Noce Tan hat eine natürliche Farbe mit ausgeprägten Hell-Dunkel-Effekten, sie ist mit transparentem Acryl lackiert und leicht gebürstet.

Das Olmo Smoke wird durch eine Autoklav-Räucherbehandlung natürlich verdunkelt, mit transparentem Acryl lackiert und gebürstet.

Die ausgewählt Hölzer

Holz ist ein Material, das seine Einzigartigkeit und Originalität hat. Aufgrund dieser Eigenschaft können Unterschiede in Körnung und Farbtönen gefunden werden, die innerhalb der von den Normen vorgegebenen Toleranzen liegen.

La propuesta de maderas está diseñada para aquellos que prefieren un material con un encanto natural.

Presenta una amplia selección de acabados de madera contrachapada para consoles, muebles y frentes, tratados para su uso en el baño.

El roble y el walnut naturales (nogal americano) se barnizan con acrílico transparente.

El roble Vintage y el roble termotratado se obtienen de postes de roble (briccola) o plantas muy nudosas con la característica diversidad de colores debida a la exposición a los agentes atmosféricos. Presentan grietas medulares y nódulos abiertos en forma de estrella. La chapa del roble Vintage se completa con soporte negro o claro para destacar el acabado dividido.

La madera termotratada es un tri-capa tratada a altas temperaturas que se barniza con acrílico transparente con divisiones parcialmente rellenas en negro o blanqueadas.

La chapa del roble Termocotto se trata a altas temperaturas y se pinta en acrílico transparente

El Noce Tan tiene un color natural con marcados efectos de claroscuro, está pintado en acrílico transparente, con un ligero cepillado.

El Olmo Smoke se oscurece naturalmente con un tratamiento de ahumado en autoclave, pintado en acrílico transparente y cepillado.

Las maderas seleccionadas

La madera es un material que tiene su singularidad y originalidad. Debido a esta característica, se pueden encontrar diferencias en los tonos de grano y color que caen dentro de las tolerancias establecidas por los estándares.

Legno

Holz

Madera

Manutenzione e pulizia

Pulire con panno morbido o spugna non abrasiva umida utilizzando detergenti neutri non abrasivi. Al termine dell'operazione di pulizia risciacquare bene la superficie. Non utilizzare solventi chimici aggressivi quali acetone, trielina e solventi. In caso di macchie persistenti utilizzare un panno morbido con sapone neutro. Si consiglia di provare qualsiasi prodotto nella parte interna della superficie, in un angolo, prima di utilizzarlo nella parte esterna. Asciugare accuratamente le superfici dopo l'uso.

Wartung und Reinigung

Mit einem weichen feuchten Tuch oder einem nicht-scheuernden Schwamm mit einem milden, nicht scheuernden Reinigungsmittel reinigen. Nach der Reinigung spülen Sie die Oberfläche gut ab. Verwenden Sie keine scharfen chemischen Lösungsmitteln, wie Aceton, Trichlorethylen oder Lösungsmittel, Verwenden Sie bei hartnäckigen Flecken ein weiches Tuch mit milder Seife. Wir raten dazu alle Produkte erst auf der Innenfläche, in einer nicht sichtbaren Ecke zu testen bevor Sie es an der Außenseite verwenden. Trocknen Sie die Flächen nach dem Gebrauch gründlich ab.

Mantenimiento y limpieza

Limpiar con un paño suave o esponja no abrasiva húmeda, utilizando detergentes neutros no abrasivos. Al finalizar la operación de limpieza aclarar bien la superficie. No utilizar disolventes químicos agresivos como acetonas, tricloroetileno y disolventes. En caso de manchas resistentes utilizar un paño suave con jabón neutro. Se aconseja probar el producto sobre la parte interna de la superficie, en un ángulo, antes de utilizarlo sobre la parte externa. Secar bien las superficies tras el uso.



Impiallacciato vero legno
Echtholz furnier
Chapado de madera auténtica



Facile da pulire
Leicht zu reinigen
De fácil limpieza

Gres

Il gres è un Porcellanato ceramico ultrasottile di alta qualità, di nuova concezione che fa della versatilità e della facilità di impiego i suoi punti di forza. È resistente ma leggero, planare ma flessibile e facilmente igienizzabile, totalmente ecosostenibile e in grado di portare a livelli d'eccellenza le qualità delle piastrelle di gres porcellanato.

Manutenzione e pulizia

Pulire con panno o spugna umida utilizzando detergenti neutri non abrasivi, diluiti in acqua calda. Al termine dell'operazione di pulizia risciacquare bene la superficie. Non utilizzare solventi chimici aggressivi.

Gres ist ein Porzellan-Keramik von extremer Dünne und hoher Qualität, von neuem Design, das aus der Vielseitigkeit und Benutzerfreundlichkeit seine Stärken macht. Es ist stark, aber leicht, eben, jedoch flexibel und leicht zu reinigen, völlig umweltfreundlich und in der Lage die Qualitäten der Fliesen aus Porzellan Gres auf ein Niveau der Exzellenz zu führen.

Wartung und Reinigung

Mit einem feuchten Tuch oder einem Schwamm mit einem milden, nicht scheuernden, in warmen Wasser verdünntem Reinigungsmittel reinigen. Nach der Reinigung spülen Sie die Oberfläche gut ab. Verwenden Sie keine scharfen chemischen Lösungsmitteln.

El gres es una porcelana cerámica ultrafina de alta calidad, de nueva concepción, que tiene sus puntos fuertes en la versatilidad y la facilidad de empleo. Es resistente pero ligera, plana y flexible y fácilmente saneable, totalmente ecosostenible y capaz de llevar a niveles de excelencia las calidades de los azulejos de gres porcelánico.

Mantenimiento y limpieza

Limpiar con un paño o esponja húmeda, utilizando detergentes neutros no abrasivos, diluidos en agua caliente. Al finalizar la operación de limpieza aclarar bien la superficie. No utilizar disolventes químicos agresivos como acetonas, tricloroetileno y disolventes.



Igienico
hygienisch
Higiénico



Facile da pulire
Leicht zu reinigen
De fácil limpieza



Resistente ai graffi
Kratzfest
Resistente a los arañazos

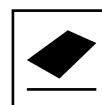

Planare e sottile
Eben und dünn
Plano y delgado

Materiale innovativo creato per l'interior design. La parte esteriore di FENIX NTM®, è ottenuta con l'ausilio di nanotecnologie ed è caratterizzata da una superficie decorativa trattata con resine termoplastiche di nuova generazione che rendono la superficie estremamente opaca, con bassa riflessione della luce, anti-impronta, morbida al tatto e consentono riparabilità termica dei micrograffi. Inoltre, FENIX NTM® è un materiale resistente ai graffi, strofinamento, abrasione e urto, con alta attività di abbattimento della carica batterica, igienico, facile da pulire, antimuffa, antistatico, idrorepellente e resistente al calore secco.

Manutenzione e pulizia

Pulire con panno morbido o spugna non abrasiva umida utilizzando detergenti neutri non abrasivi. Al termine dell'operazione di pulizia risciacquare bene la superficie. Non utilizzare solventi chimici aggressivi quali trielina, solventi, prodotti cerati, candeggianti o clorati. Per macchie resistenti utilizzare alcool o acetone e panno morbido.

Ein innovative Material geschaffen für den Innenausbau. Das Äußere von FENIX NTM®, wird mit Hilfe von Nanotechnologie erhalten und besteht aus einer dekorativen Oberfläche die mit thermoplastischen Harzen der neuesten Generation behandelt wird, die die Oberfläche extrem undurchsichtig machen, mit geringer Lichtreflexion, Anti-Abdruckeffkt, weich bei der Berührung und die die thermische von Mikrokratzern ermöglicht. Darüber hinaus ist NTM FENIX™ ein Material, das resistent gegen Kratzer, Reibung, Verschleiß und Stößen ist, mit einer starken Aktivität der Abtötung von Bakterien, hygienisch, leicht zu reinigen, Anti-Schimmel, antistatisch, wasserabweisend und resistent gegen trockene Hitze.

Wartung und Reinigung

Mit einem weichen feuchten Tuch oder einem nicht-scheuernden Schwamm mit einem milden, nicht scheuernden Reinigungsmitteln reinigen. Nach der Reinigung spülen Sie die Oberfläche gut ab. Verwenden Sie keine scharfen chemischen Lösungsmitteln, wie Trichlorethylen Lösungsmittel, Wachsprodukte, Bleichmittel oder Chlor. Bei hartnäckigen Flecken verwenden Sie Alkohol oder Aceton und ein weiches Tuch.

Material innovador creado para el diseño de interiores. La parte exterior de FENIX NTM® se obtiene con ayuda de la nanotecnología y se caracteriza por una superficie decorativa tratada con resinas termoplásticas de nueva generación, que hacen que la superficie resulte extremadamente mate, con baja reflexión de la luz, antihuellas, suave al tacto y permiten la reparación térmica de los microarañazos. Además, FENIX NTM™ es un material resistente a los rasguños, a la fricción, la abrasión y los golpes, con elevada actividad de reducción de la carga bacteriana, higiénico, de fácil limpieza, antihongos, antiestático, hidrófugo y resistente al calor seco.

Mantenimiento y limpieza

Limpiar con un paño suave o esponja no abrasiva húmeda, utilizando detergentes neutros no abrasivos. Al finalizar la operación de limpieza aclarar bien la superficie. No utilizar disolventes químicos agresivos como tricloroetileno, disolventes, productos de encerado, blanqueadores o clorados. Para manchas resistentes utilizar alcohol o acetona y un paño suave.



Certificato per pannelli in melamminico e MDF a garanzia di utilizzo di pannelli con emissioni di formaldeide inferiori al minimo imposto dalla norma europea UNI EN13896.

Zertifikat für Melaminplatten und MDF-Platten, die den Einsatz von Platten mit geringeren Formaldehyd-Emissionen als die die von der Europäischen Norm UNI EN13896 gefordert werden, garantieren.

Certificado para paneles de melamina y MDF que garantiza la utilización de paneles con emisiones de formaldehído inferiores al mínimo estipulado por la norma europea UNI EN13896.



Certificato di trattamento del pannello con resine idrorepellenti.

Zertifikat über die Behandlung der Platte mit wasserabweisenden Harzen.

Certificado de tratamiento del panel con resinas hidrófugas.



Superficie estremamente opaca, bassa riflessione della luce
Extrem matte Oberfläche, geringe Lichtreflexion
Superficie extremadamente mate, baja reflexión de la luz.



Resistente ai graffi
Kratzfest
Resistente a los arañazos



Anti-impronta
Anti-Abdruck
Sin huellas

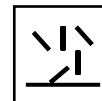

Antimuffa
Anti-Schimmel
Antimohos



Igienico
hygienisch
Higiénico



Facile da pulire
Leicht zu reinigen
De fácil limpieza